



# Strojimport

TOSHULIN GROUP

CATALOGUE  
MACHINERY  
2021



## CONTENT

1	LATHES
2	HORIZONTAL BORING AND MILLING MACHINES
3	MILLING MACHINES
4	GRINDING MACHINES
5	DRILLING MACHINES
6	GEAR CUTTING MACHINES
7	CENTRES
8	PRESS MACHINES
9	ROLLING MACHINES
	INCOTERMS 2020
	WE OFFER & PROVIDE

We reserve the right to change the terms and conditions.

We are not responsible for printing errors

The manufacturer reserves the right to change the product parameters and design without prior notice.



## **Expert not only on CNC machines.**

Are you looking for a reliable, stable and experienced supplier of machine tools, forming machines and other machinery? We rank among the most significant exporters of Czech and Slovak machine tools and forming machines. To a large extent, we have contributed to famous brand reputation throughout the world. This cooperation could be of interest to you mainly due to so many years of experience in the engineering field – Strojimport has been active on world markets continuously since 1953 and has know-how in dealing with both Czech and foreign partners.

We deliver high-performance, high-quality and high-precision machine tools and forming machines produced by renowned Czech and Slovak manufacturers to customers all around the world. Besides Europe, we focus mainly on the markets of Africa, South America, Arab countries, Southeast Asia and the Far East, Australia and New Zealand. We have our own offices or agents all around the world.

In our wide range of machines, that contains more than 200 types, you will find lathes, horizontal borers, mills, grinders, drills, machining centers, gear cutting machines, presses, forging presses, rolling machines, bending machines, shears, and many other special machines. We also deal with export of materials, investment units, engineering and technological business, warranty and after-warranty service including supply of spare parts, tools and accessories.

## **Do you have older machines? Let them have overhauled.**

We also carry out modernization and overhauling of machine tools and forming machines, as well as supply of original spare parts and accessories to the machines that were manufactured in the former Czechoslovakia. This is definitely more cost-effective compared to a new machine purchase, with lower requirements as for newly trained staff. We can also buy back your old machine.

## **We operate also in other areas.**

We do not deal with machine tools export and import only. We also specialize in trading operations – export of materials (steel, pipes, sheet metal, plastic granulate etc.), investment units, production lines, import of machines and spare parts for machines imported in the past. We offer complete turnkey projects. Within the entire era of operation, we have gained position of a reliable and stable partner with extensive experience and envoy of the latest technologies in the foreign markets.



# 1 LATHES

## UNIVERSAL CENTER LATHES



**TRENS**

UNIVERSAL CENTER LATHES		SN 32	SN 50 C	SN 71 C	SUI 80
Swing over bed	(mm)	330	500	710	800
Swing over cross slide	(mm)	168	270	420	520
Spindle bore	(mm)	52	52	73,5	92
Spindle speed range	(min <sup>-1</sup> )	14 ÷ 2500	22 ÷ 2000	10 ÷ 1000	14 ÷ 1400
Distance between centres (DBC)	(mm)	750, 1000	1000, 1500, 2000	1500, 2000, 3000, 4000	1500 ÷ 8000
Max. workpiece weight	(kg)	132	300	1500	3200
Total power output- main drive	(kW)	4	5,5	7,5 (11)	15 (18,5)



**TRENS**

UNIVERSAL CENTER LATHES		SN 500 SA	SN 710 S
Swing over bed	(mm)	505	720
Swing over cross slide	(mm)	270	430
Spindle bore	(mm)	77 (105)	77 (105, 130)
Spindle speed range	(min <sup>-1</sup> )	12,5 ÷ 2000	10 ÷ 1600
Distance between centres (DBC)	(mm)	1000, 1500, 2000	1500 ÷ 4000
Max. workpiece weight	(kg)	1000	1500
Total power output- main drive	(kW)	7,5	7,5 (11, 15)



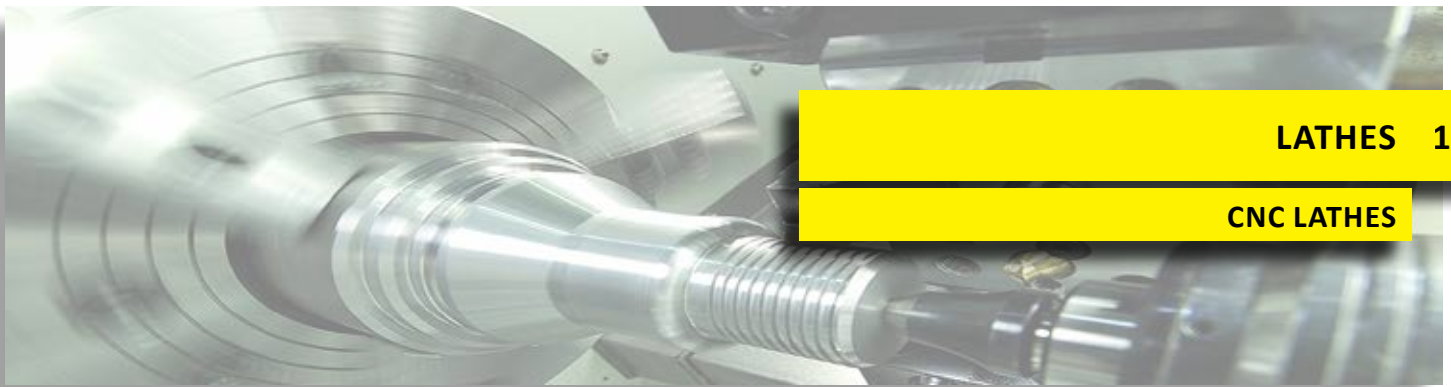

TRENS



CNC LATHES		SE 320 NUMERIC	SE 520 NUMERIC	SE 520 SL NUMERIC	SE 820 NUMERIC	SE 1020 NUMERIC
Swing over bed	(mm)	320	520	520	800	1020
Swing over cross slide	(mm)	170	290	290	515	740
Spindle bore	(mm)	42 (57)	77 (105)	75 (103)	133	133
Spindle speed range	(min <sup>-1</sup> )	1 ÷ 880 / 1 ÷ 3500	7 ÷ 650 / 30 ÷ 2600	7 ÷ 650 / 30 ÷ 2600	1 ÷ 1600	1 ÷ 1600
Distance between centres (DBC)	(mm)	750	950, 1450	2000	2000, 3000, 4000, 6000, 8000	2000, 3000, 4000, 6000, 8000
Main motor output	(kW)	7	11	11	30	30



MAS  
KOVOSVIT MAS  
Turning your future

CNC LATHES		MASTURN 550i CNC 800 / 1500	MASTURN 550i LIVE TOOL 1500	MASTURN 820i 2000 / 3000	MASTURN 820i 4500
Swing dia. over bed	(mm)	550	550	820	820
Swing over cross slide	(mm)	350	350	530	530
Distance between centres	(mm)	900 / 1600	1600	2000 / 3000	4500
Spindle bore	(mm)	82	82	128	128
Spindle nose (DIN 55027)	-	B8, C8	B8, C8	B11, C11	B11, C11
Control system	-	HEIDENHAIN / SIEMENS	HEIDENHAIN	HEIDENHAIN / SIEMENS	HEIDENHAIN / SIEMENS
Motor output	(kW)	17	17	28 / 22	28 / 22
Spindle speed range (rpm)	(min <sup>-1</sup> )	0 ÷ 3000	0 ÷ 3000	0 ÷ 1800	0 ÷ 1800
Max. spindle torque	(Nm)	1620	1620	2500 / 3000	2500 / 3000
Max. travel axis X / Z	(mm)	285 × 890 (1590)	267 × 1517	370 × 2000 (3000)	370 × 4 500



# 1 LATHES

## CNC LATHES



CNC LATHES		SUA 63 NUMERIC	SUA 80 NUMERIC	SUA 100 NUMERIC	SUA 125 NUMERIC	SUA 150 NUMERIC
Swing over bed	(mm)	655	840	1050	1250	1500
Swing over cross slide	(mm)	380	530	720	930	1190
Spindle bore	(mm)	128	128	128	128	128
Spindle speed range	(min <sup>-1</sup> )	5 ÷ 1250	5 ÷ 1250	4 ÷ 630	4 ÷ 630	4 ÷ 630
Distance between centres (DBC)	(mm)	2000 ÷ 12500	2000 ÷ 14000	2000 ÷ 20000	2000 ÷ 20000	2000 ÷ 20000
Max. workpiece weight	(kg)	6000 / 8000	6000 / 8000	6000 / 8000	6000 / 8000	6000 / 8000
Main motor output	(kW)	30	30	37	37	37

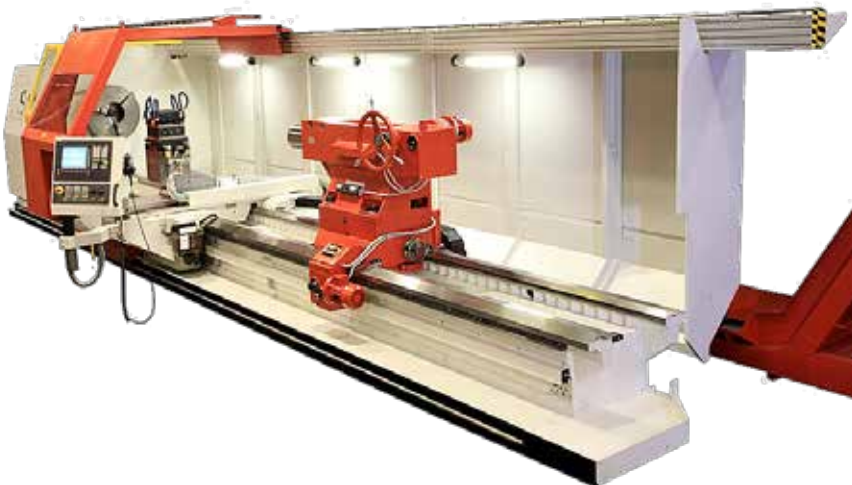

CNC LATHES WITH SLANT BED

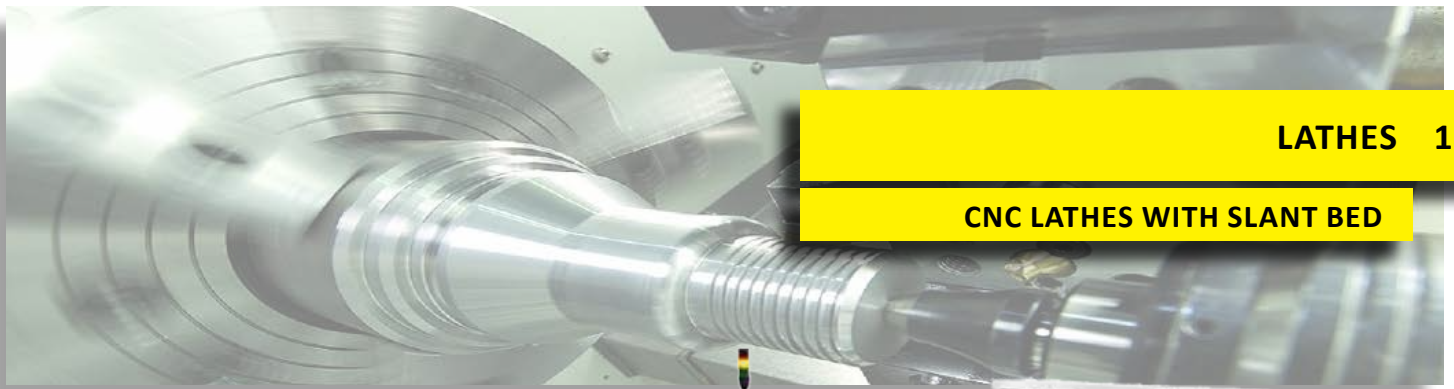

TRENS

CNC LATHES WITH SLANT BED		SBL 300 CNC	SBL 500 CNC	SBL 700 CNC	SBE 300 CNC	SBX 500
Swing over bed	(mm)	530	630	750	530	650
Swing over cross slide	(mm)	260	410	500	320	550
Main spindle bore	(mm)	56 (65, 92)	92 (133)	127	65	92 (133)
Main spindle speed range	(min <sup>-1</sup> )	4000 (5000, 3500)	4200 (2500)	2500	4000	4000 (2800)
Distance between centres (DBC)	(mm)	485 (500)	750, 1500	2000	500	800 (1500)
Main drive motor output	(kW)	7 (9, 11, 15)	22 (30)	37	11 (15)	22 (30,8)



MAS

KOVOSVIT MAS

CNC LATHES WITH SLANT BED CNC LATHES FOR MACHINING COMPLICATED SHAFT SHAPES		SPH 50	SPH 50D	SPH 50DS
Swing dia. over bed	(mm)	760 (910)	760	760
Max. dia right/left saddle turning	(mm)	530 / 530	530 / 400	530 / 400
Max. turning length	(mm)	3000	2800	2700
X-Axis- max. travel	(mm)	225 (Ø84 ÷ 530)	280 (Ø ÷ 530)	280 (Ø ÷ 530)
Z-Axis- max. travel	(mm)	2385	2620	2600
U-Axis- max. travel	(mm)	225 (Ø88 ÷ 530)	200 (Ø30 ÷ 400)	200 (Ø30 ÷ 400)
W-Axis- max. travel	(mm)	1810	2030	2030



# 1 LATHES

## CNC LATHES WITH LIVE TOOLS

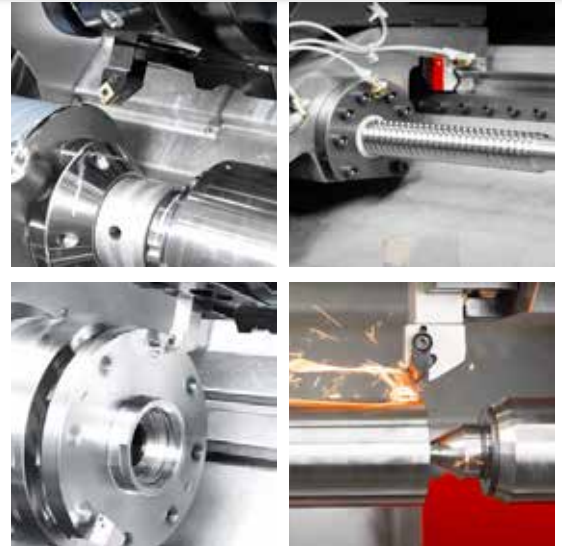

CNC LATHES WITH LIVE TOOLS		KL 285	KL 285 MC	KL 285 Y	KL 285 SMC	KL 285 SY
Swing dia. over bed	(mm)	670	670	670	670	670
Max. turning dia.	(mm)	340	340	340	304	304
Max. turning length A5/A6	(mm)	550	550	550	---	---
Max. travel axis X / Z	(mm)	243 × 610	243 × 610	243 × 610	168 × 610	168 × 610
Spindle speed	(min <sup>-1</sup> )	5000	5000	5000	5000	5000
Tool head- Number of positions	-	12	12	12	12	12



CNC LATHES WITH LIVE TOOLS		KL 435	KL 435MC	KL 435Y
Swing dia. over bed	(mm)	700	700	700
Max. turning dia.	(mm)	550	550	550
Max. turning length A5/A6	(mm)	1100	1100	1100
Max. travel axis X / Z	(mm)	345 × 1225	345 × 1225	325 × 1225
Spindle speed	(min <sup>-1</sup> )	3800	3800	3800
Tool head- Number of positions	-	12	12	12



MULTI-FUNCTIONAL TURN-MILL CENTERS



MULTI-FUNCTIONAL TURN-MILL CENTERS		MULTICUT 500i S	MULTICUT 500i T	MULTICUT 500i S POWER	MULTICUT 500i T POWER	MULTICUT 630 MULTI-VARIANT
Turning dia. (B=45°)	(mm)	690	690	690	690	930
Max. milled profile	(mm)	486 × 486	486 × 486	486 × 486	486 × 486	1600 (3100, 4600, 6100)
Max. machining length	(mm)	1527	1693	1527	1693	1700 (3200, 4700, 6000)
Max. bar stock dia.	(mm)	94	94	127	127	127
Spindle output S1 and S2 (S1/S6 40%)	(kW)	59 / 74	59 / 74	28 / 42	28 / 42	41 / 61,5
Max. spindle speed S1 and S2	(min <sup>-1</sup> )	3500	3500	2800	2800	2800
Max. torque	(Nm)	1400 (2100)	1400 (2100)	1400 (2100)	1400 (2100)	1408 (2176)
Spindle	-	HSK- A 63 (Capto C6)	HSK- A 63 (Capto C6)	HSK- A 63 (Capto C6)	HSK- A 63 (Capto C6)	HSK T63, Capto C6
Spindle output (S1/S6 40%)	(kW)	13,2 / 22	13,2 / 22	13,2 / 22	13,2 / 22	25 / 30 (37 / 47, 29 / 37, 38 / 47)
Max. spindle speed S3 (rpm)	(min <sup>-1</sup> )	12000	12000	12000	12000	12000 (10000, 6500, 3500)
Max. B axis swivelling angle	(°)	-120 / +105	-120 / +105	-120 / +105	-120 / +105	-120 / +120
Max. swivelling angle	(min <sup>-1</sup> )	50	50	50	50	50
Number of pockets in tool magazine		81	81	81	81	HSK-T63, Capto C6 66 [120,180] HSK-T100, Capto C8 44 [80,120]



# 1 LATHES

## MULTI-FUNCTIONAL TURN-MILL CENTERS

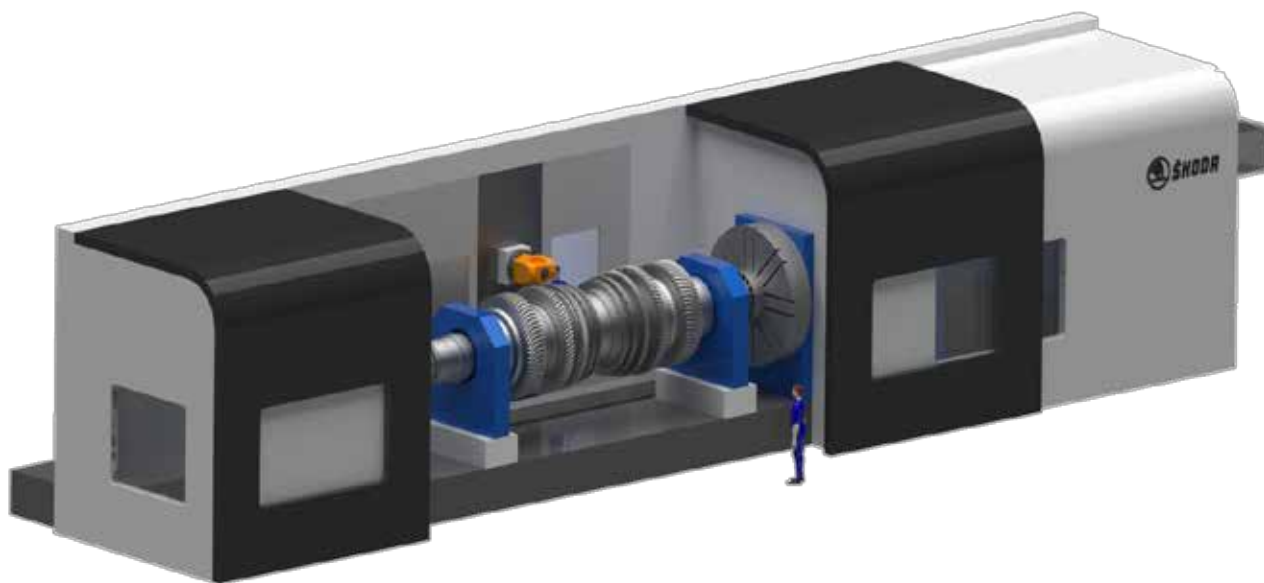

UNIVERSAL HORIZONTAL LATHES MULTI-FUNCTIONAL MACHINE TYPE S-MT		S 150 MT	S 200 MT	S 320 MT	S 500 MT
Turning dia. (B=45°)	(mm)	1500	2000	3200	5000
Max. milled profile	(mm <sup>3</sup> )	700	400	300	200
Max. machining length	(kg)	32000	70000	160000	250000
Max. bar stock dia.	(mm)	4000 ÷ 10000	4000 ÷ 10000	5000 ÷ 15000	5000 ÷ 15000
Spindle output S1 and S2 (S1/S6 40%)	(kW)	71	95	190	190

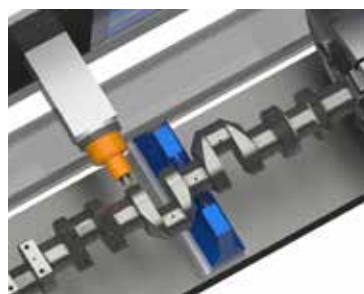
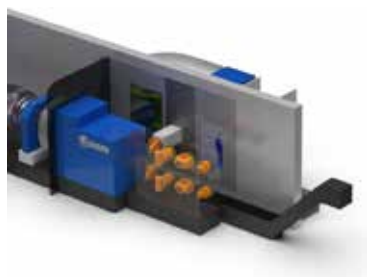



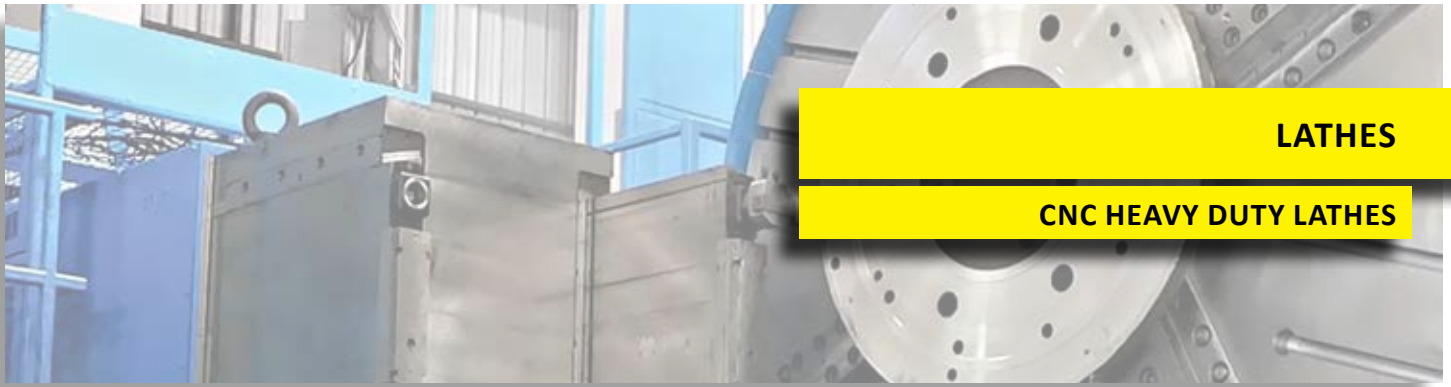

# LATHES

## CNC HEAVY DUTY LATHES



CNC HEAVY DUTY LATHES		SR 1	SR 2	SR 3	SR 4	SR 5
Swing over carriage	(mm)	1000 / 1300 / 1500	1300 / 1600 / 2000	2000 / 2500 / 3000	3000 / 3300 / 3600	3600 / 4200 / 5200
Spindle speed	(min <sup>-1</sup> )	1 ÷ 1000 / 1 ÷ 700	1 ÷ 700 / 1 ÷ 400 / 1 ÷ 250	1 ÷ 400 / 1 ÷ 250 / 1 ÷ 200	1 ÷ 400 / 1 ÷ 250 / 1 ÷ 200 / 1 ÷ 120	1 ÷ 400 / 1 ÷ 200 / 1 ÷ 120
Max. workpiece weight	(t)	25	56	100	250	350
Workpiece length	(mm)	3000 ÷ 20000	4000 ÷ 20000	4000 ÷ 20000	4000 ÷ 20000	4000 ÷ 30000
Main drive motor power	(kW)	60 / 100	60 / 100 / 140 / 200	60 / 100 / 140 / 200	60 / 100 / 140 / 200	60 / 100 / 140 / 200 / 330



# 1 LATHES

## MULTISPINDLE AUTOMATIC LATHES



MULTISPINDLE AUTOMATIC LATHES	MORI-SAY 620(S)AC	MORI-SAY 632(S)AC MORI-SAY 642(S)AC	MORI-SAY 657(S)AC MORI-SAY 667AC	MORI-SAY TMZ518CNC/PENTA	MORI-SAY TMZ642CNC
Number of spindles	6	6	6	5	6
Max. diameter of bar (mm)	20	32 / 42	57 / 67	19	42
Drilling of clamping pipe (mm)	28	43 / 53	66 / 78		53
Max. length of feeding (mm)	100	125	160	100	180
Maximum revolutions AC (min <sup>-1</sup> )	500 ÷ 6000	250 ÷ 4250	200 ÷ 3200	8000	5000
Maximum revolutions SAC (min <sup>-1</sup> )	500 ÷ 4500	250 ÷ 3350	200 ÷ 2750	---	---
Main motor (kW)	9	22	30	7,5	7



MULTISPINDLE AUTOMATIC LATHES	MORI-SAY 832(S)AC MORI-SAY 842(S)AC	MORI-SAY TMZ842CNC	MORI-SAY TMZ867CNC
Number of spindles	8	8	8
Max. diameter of bar (mm)	32 / 42	42	67
Drilling of clamping pipe (mm)	43 / 53		78
Max. length of feeding (mm)	125	180	200
Maximum revolutions AC (min <sup>-1</sup> )	270 ÷ 3750	4500	2500
Maximum revolutions SAC (min <sup>-1</sup> )	270 ÷ 3200	---	---
Main motor (kW)	37	88	30

SWISS-TYPE LATHES

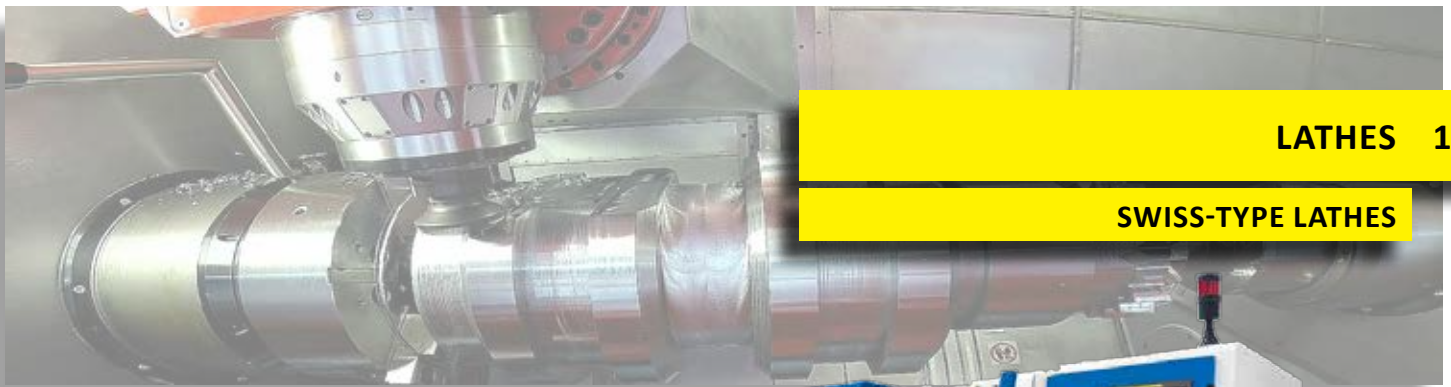

SWISS-TYPE LATHES	MANURHIN K'MX413	MANURHIN K'MX432	MANURHIN K'MX532 TREND	MANURHIN K'MX632DUO	MANURHIN K'MX732EVO
Number of CNC axes	4 + 2	4 + 2	5 + 2	6 + 2	7 + 2
Spindle stroke (mm)	130	410	410	410	410
Spindle bore (mm)	∅ 18 (19)	∅ 37	∅ 37	∅ 37	∅ 37
Max. diameter of bar stock (mm)	∅ 13 (16)	∅ 32 (36)	∅ 32 (36)	∅ 32 (36)	∅ 32 (36)
Spindle power (100% / 30min. - main) (kW)	3,7 / 5,5	5,5 / 7,5	5,5 / 7,5	5,5 / 7,5	15 / 25
Maximum spindle speed (min <sup>-1</sup> )	12000	10000	10000	10000	8000



SWISS-TYPE LATHES	MANURHIN K'MX816 CLEVER	MANURHIN K'MX916 CLEVER	MANURHIN K'MX SWING
Number of CNC axes	8 + 2	9 + 2	10 + 2
Spindle stroke (mm)	220	220	250
Spindle bore (mm)	∅ 21 (23)	∅ 21 (23)	∅ 33
Max. diameter of bar stock (mm)	∅ 16 (20)	∅ 16 (20)	∅ 26 (32)
Spindle power (100% / 30min. - main) (kW)	3,7 / 5,5	3,7 / 5,5	5,5 / 7,5
Maximum spindle speed (min <sup>-1</sup> )	12000	12000	8000





# 1 LATHES

## VERTICAL TURNING LATHES

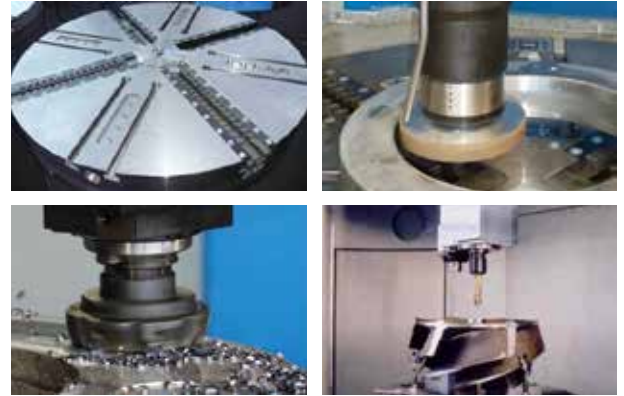

**TOSHULIN**

VERTICAL TURNING LATHES	BASICTURN 1250	BASICTURN 1600	BASICTURN 2000	BASICTURN 2500	BASICTURN 3000	BASICTURN 4000
Table diameter (mm)	1250	1600	2000	2500	3000	4000
Maximum workpiece diameter (mm)	1400	2000	2300	2900	3600	5000
Maximum workpiece height (mm)	1400 (1900)	1500 (2000)	1500 (2000)	1940 (2540)	1940 (2540)	1800 (2480)
Maximum workpiece weight (kg)	8000	12000	20000	25000	25000	25000
Maximum table speed (min <sup>-1</sup> )	400 (500, 630)	315 (400)	250 (315)	200 (250)	200	150
Main motor power output (Siemens / Fanuc) (kW)	44 (58) / 45 (60)	58 (81) / 60 (75)	58 (81) / 60 (75)	58 (81) / 60 (75)	58 (81) / 60 (75)	58 (81) / 60 (75)

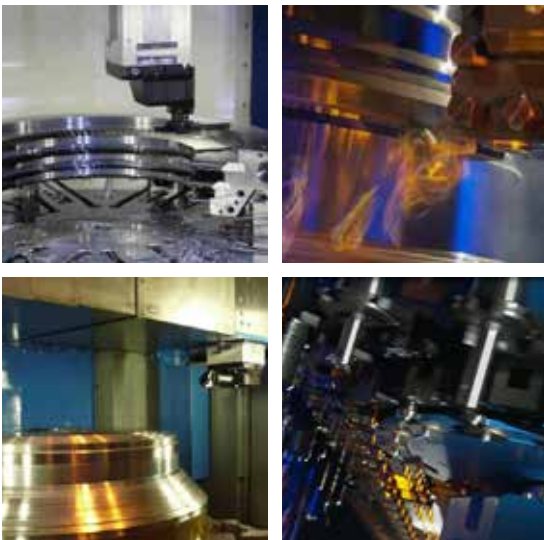

**TOSHULIN**

VERTICAL TURNING LATHES POWERTURN	POWERTURN 800	POWERTURN 1000	POWERTURN 1250	POWERTURN 1600	POWERTURN 2000	POWERTURN 2500	POWERTURN 3000	POWERTURN 4000
Table diameter (mm)	800	1000	1250	1600	2000	2500	3000	4000
Maximum workpiece diameter (mm)	1000	1400	1500	2000	2300	2900	3600	5000
Maximum workpiece height (mm)	1300 (1400)	1300 (1800)	1300 (1800)	1400 (1900), 2100, 2500	1400 (1900), 2100, 2500	1800 (2440, 3140)	1800 (2440, 3140)	1780 (2380, 3080)
Maximum workpiece weight (kg)	4000	6500	8000	12000	20000	25000	25000	30000
Maximum table speed (min <sup>-1</sup> )	400 (500, 630)	400 (500, 630)	400 (500, 630)	315 (400)	250 (315)	200 (250)	200	150
Main motor power output (Siemens / Fanuc) (kW)	44 (58) / 45 (60)	44 (58) / 45 (60)	44 (58) / 45 (60)	58 (81) / 60 (75)	58 (81) / 60 (75)	58 (81) / 60 (75)	81 (105) / 75 (100)	81 (105) / 75 (100)



VERTICAL TURNING LATHES



VERTICAL TURNING LATHES	FORCETURN 2500	FORCETURN 3000	FORCETURN 4000
Table diameter (mm)	2500	3000	4000
Maximum workpiece diameter (mm)	2900	3600	5000
Maximum workpiece height (mm)	2500 (3500, 4000)	2500 (3500, 4000)	2500 (3500, 4000, 5000)
Maximum workpiece weight (kg)	45000 / 30000	45000 / 30000	60000 / 40000
Maximum table speed (min <sup>-1</sup> )	200 / 250	200 / 200	125 / 150
Main motor power output (Siemens / Fanuc) (kW)	2x 58 (2x 71) / 2x 60 (2x 75)	2x 58 (2x 71) / 2x 60 (2x 75)	2x 58 (2x 71) (2x 105) / 2x 60 (2x 75) (2x 100)



VERTICAL TURNING LATHES	EXPERTURN 2000 S
Table diameter (mm)	2000
Maximum workpiece diameter (mm)	2500
Maximum workpiece height (mm)	400
Maximum workpiece weight (kg)	1300
Main motor power output (kW)	58



VERTICAL TURNING LATHES	EXPERTURN
-------------------------	-----------

Execution and technical parameters in accordance with the customer's requirements

# 1 LATHES

## VERTICAL TURNING LATHES

**ČKD BLANSKO-OS**

### SINGLE COLUMN VERTICAL TURNING LATHES

		SKJ 63-100	SKJ 80-160
Clamping plate diameter	(mm)	6300	8000
Max. turning diameter	(mm)	10000	16000
Max. turning height	(mm)	3000	6300
Max. workpiece weight	(kg)	150000	320000
Max. turning table speed	(min <sup>-1</sup> )	35	25
Ram cross-section	(mm)	340 × 340	450 × 450
Cutting force	(kN)	100	125

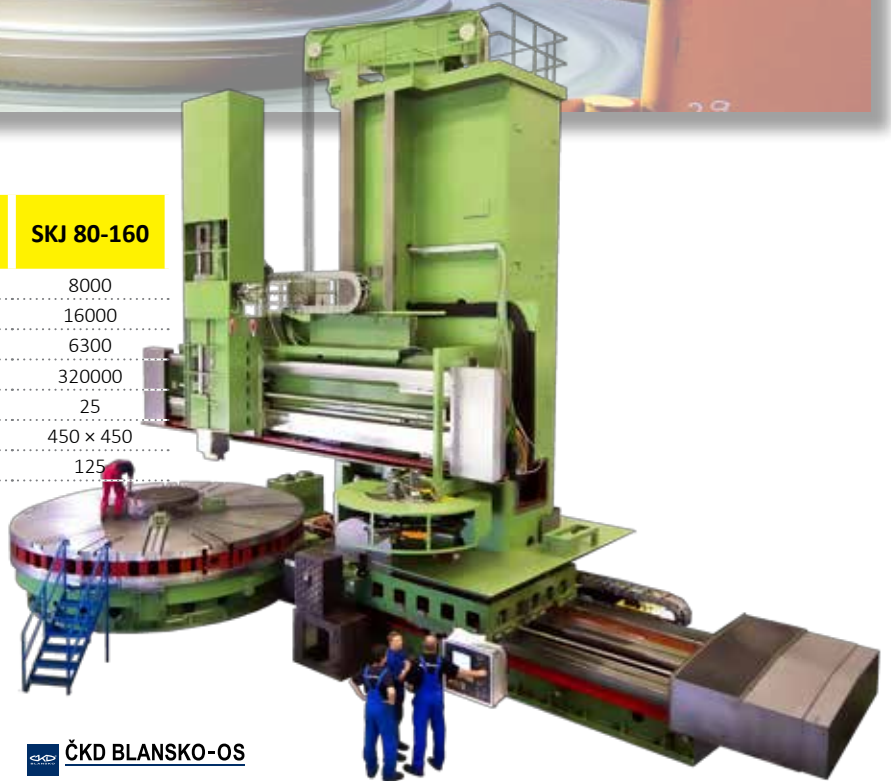

**ČKD BLANSKO-OS**

### DOUBLE COLUMN VERTICAL TURNING LATHES

		SKD 50	SKD 50-80
Clamping plate diameter	(mm)	5000	5000 ÷ 8000
Max. turning diameter	(mm)	6000	6500 ÷ 10000
Max. turning height	(mm)	2000 / 2800	4000 ÷ 6000
Max. workpiece weight	(kg)	100000	100000 ÷ 320000
Max. turning table speed	(min <sup>-1</sup> )	60	60 ÷ 25
Ram cross-section	(mm)	340 × 340	340 × 340 / 400 × 400
Cutting force	(kN)	40	100

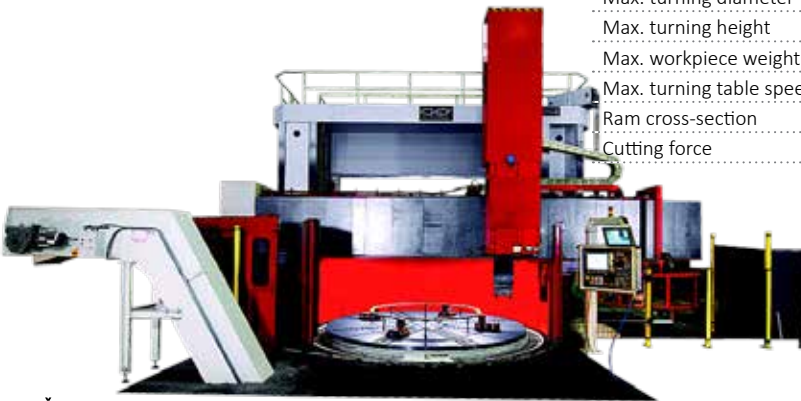

**ČKD BLANSKO-OS**

### DOUBLE COLUMN VERTICAL TURNING LATHES

		SKDY 40-50	SKDY 40-80
Table diameter	(mm)	4000 / 5000	4000 ÷ 8000
Max. turning diameter	(mm)	5000 / 6000	5000 ÷ 10000
Max. turning height	(mm)	2000 / 2800	4000 ÷ 6000
W axis cross-rail travel	(mm)	1500 / 2000	2800 ÷ 4800
Y axis travel	(mm)	4000 / 5000	4500 ÷ 6500
Z axis travel of ram	(mm)	2000 / 2500	2500 / 3200
Workpiece weight	(kg)	30000 ÷ 100000	50000 ÷ 320000
Turning table speed	(min <sup>-1</sup> )	125 ÷ 50	125 ÷ 25
Ram cross-section	(mm)	340 × 340	340 × 340 / 400 × 400





# HORIZONTAL BORING AND MILLING MACHINES

2

## TABLE TYPE



**RETOS**  
VARNŠKOP

TABLE TYPE		W 100A	RET 100B CNC	RET10X
Workspindle diameter	(mm)	100	100	100 / 105
Clamping taper	(ISO)	50	50	50
Table transverse travel X	(mm)	1600	1600	1000, 1250, 1500, 1750, 2000 (3000)
Headstock vertical travel Y	(mm)	1120	1290	1000, 1250, 1500, 1750, 2000
Table longitudinal travel Z	(mm)	810 (1250, 1750)	900 (1710)	1000, 1250, 1500, 1750, 2000
Spindle stroke W	(mm)	900	710	max. 710
Ram travel V	(mm)	-	-	650
Spindle speed range	(min <sup>-1</sup> )	1120	3000	10 ÷ 3500
Table clamping surface	(mm)	1250 × 1250 (1500 × 1500)	1250 × 1250 (1500 × 1500)	1250 × 1250, 1500 × 1500
Workpiece weight max.	(kg)	3000	3000	8000
Main motor power	(kW)	11	20	22 / 34

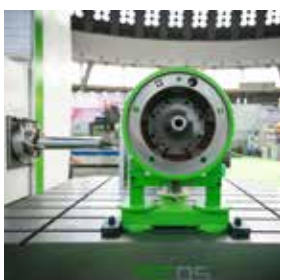



## HORIZONTAL BORING AND MILLING MACHINES

### TABLE TYPE

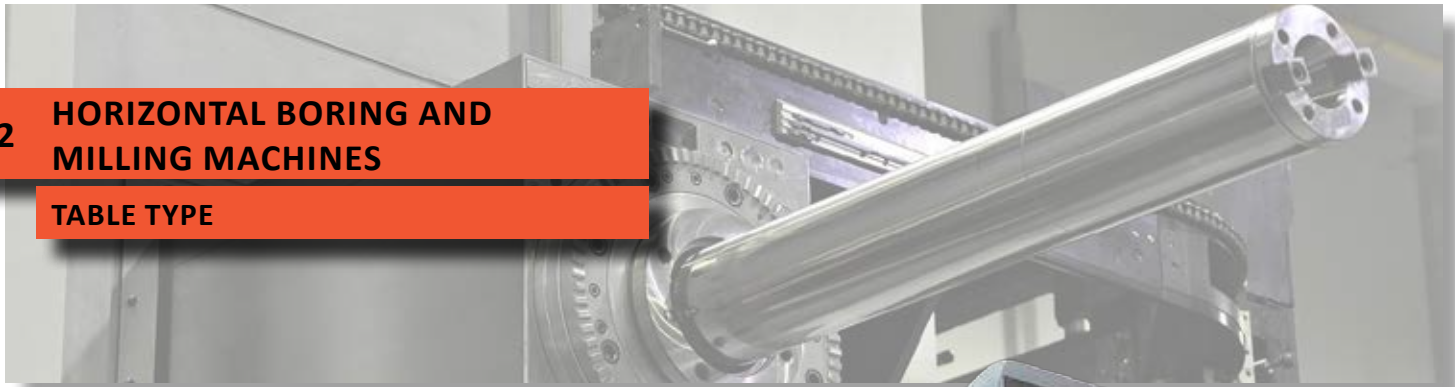
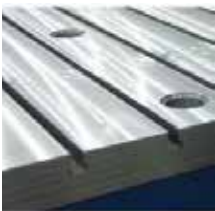

TABLE TYPE		WFC 10 CNC	WFT 11 CNC	WFT 13 CNC	WFT 15 CNC	WRFT 130 CNC
Spindle diameter	(mm)	100 (110)	110	130	150	130 (150, 160)
Clamping taper	(ISO)	50	50	50	50	50
Table transverse travel X	(mm)	1250 / 2000	2000 / 3000	2000 / 3000 / 4000 / 5000	2000 / 3000 / 4000 / 5000	2400 ÷ 6100
Headstock vertical travel Y	(mm)	1250 / 1700 / 2000	1250 / 1700 / 2000	2000 / 2500 / 3000 / 3500	2000 / 2500 / 3000 / 3500	2000 / 2500 / 3000 / 3500 / 4000
Table longitudinal travel Z	(mm)	1250	1250	1500 / 2000	2100 / 3300	900 / 2800 / 2100 / 3300 / 3900
Spindle stroke W	(mm)	730	730	730	1000	730 (1000)
Ram travel V	(mm)	---	---	600	---	900 (1000, 1200)
Spindle speed range	(min <sup>-1</sup> )	10 ÷ 2000 (3000)	10 ÷ 3000	10 ÷ 3000	10 ÷ 3000	10 ÷ 3000 (2800, 2500)
Table clamping surface	(mm)	1000 × 1120 / 1200 × 1400	1250 × 1400 / 1400 × 1600	T10- 1200 × 1400 / T15- 1600 × 1800 / 1800 × 2600 / T20- 2000 × 2400	1600 × 1800 / 1800 × 2200 / 1800 × 2600 / 2000 × 2400	2000 × 2000 / 2000 × 2500 / 2000 × 3000 / 2500 × 2500 / 2500 × 3000 / 3000 × 3000 / 25000 / 40000 / 50000
Workpiece weight max.	(kg)	3000	8000	10000 / 15000 / 20000 / 25000	15000 / 20000	3000 × 3000 / 25000 / 40000 / 50000
Main motor power	(kW)	17 / 25, 22 / 33	17 / 25, 22 / 33	37 / 56	51 / 77	37 / 56 (51 / 77, 60 / 80)



## HORIZONTAL BORING AND MILLING MACHINES

2

### TABLE TYPE



**VARNSDORF  
TOS**

TABLE TYPE		WHN 13 CNC	WHN 15 CNC	WHN 110	WHN 130	WHR 13 (Q)
Spindle diameter	(mm)	130	150	112 (125)	130 (140)	130
Table transverse travel X	(mm)	2000, 3500, 4000, 5000, 6000	2000, 3500, 4000, 5000, 6000	1600, 2000, 2500, 3000	2000, 2500, 3000, 3500, 4000	3500, 4000, 5000, 6000
Headstock vertical travel Y	(mm)	2000, 2500, 3000, 3500	2000, 2500, 3000, 3500	1250, 1400, 1600 (1120, 1250, 1400)	1600, 2000, 2500 (1400, 1800, 2240)	2000, 2500, 3000
Column longitudinal travel Z	(mm)	1250, 1600, 2200, 3200	1250, 1600, 2000, 3200	800, 1000, 1250	1000, 1250, 1600, 2000	1250, 1600, 2200, 3200
Spindle stroke W	(mm)	800	900	710 (500)	800 (560)	650
Spindle speed range	(min <sup>-1</sup> )	10 ÷ 3000 (10 ÷ 1500)	10 ÷ 3000	10 ÷ 3300	10 ÷ 3000	10 ÷ 3000
Table clamping surface	(mm)	1800 × 1800 / 1800 × 2200 / 1800 × 2500 / 2000 × 3000	1800 × 1800 / 1800 × 2200 / 1800 × 2500 / 2000 × 3000	1250 × 1400, 1400 × 1600, 1400 × 1800	1600 × 1800, 1800 × 2400	1800 × 1800 / 1800 × 2200 / 1800 × 2500 2000 × 3000 / 2500 × 3000
Workpiece weight max.	(kg)	12000 / 16000 / 18000 / 25000	12000 / 16000 / 18000 / 25000	5000	8000	12000 / 16000 / 18000 / 25000
Main motor power	(kW)	41 / 46	53 / 55	41 / 46	41 / 46	41 / 46

**VARNSDORF  
TOS**

TABLE TYPE		MAXIMA I	MAXIMA II
Spindle diameter	(mm)	130	150
Table transverse travel X	(mm)	3000, 4000, 5000*, 6000*	3000, 4000, 5000*, 6000*
Headstock vertical travel Y	(mm)	2000 ÷ 4500	2000 ÷ 4500
Ram stroke Z	(mm)	1000	1000
Spindle stroke W	(mm)	700	800
Spindle speed range	(min <sup>-1</sup> )	10 ÷ 3000	10 ÷ 2500 (2800)
Table clamping surface	(mm)	2000 × 2000, 2000 × 2500, 2500 × 3000, 3000 × 3000, 3000 × 3500, 3000 × 4000	2000 × 2000, 2000 × 2500, 2500 × 3000, 3000 × 3000, 3000 × 3500, 3000 × 4000
Workpiece weight max.	(kg)	30000	50000
Main motor power	(kW)	41 / 46	58 / 65

\* For rotary table with a load capacity of 30 tons only.





## HORIZONTAL BORING AND MILLING MACHINES

### FLOOR TYPE



**VARNSDORF**  
**TOS**

FLOOR TYPE		WRD 130	WRD 150	WRD 170	WRD 180 H	WRD 13
Spindle diameter	(mm)	130	150	170	160 / 180 / 200	130
Column transverse travel X	(mm)	5000 ÷ 27000	5000 ÷ 27000	5000 ÷ 29000	5000 ÷ 29000	3000 ÷ 20000
Headstock vertical travel Y	(mm)	2000 ÷ 4500	2000 ÷ 4500	4000 ÷ 6000	3000 ÷ 6000	2000, 2500, 3000
Spindle stroke W / Z	(mm)	700 / 1000	800 / 1000	1000 / 1500	1200 / 1600	650 / 700
Spindle speed range	(min <sup>-1</sup> )	10 ÷ 3000 (3500)	10 ÷ 2500 (2800)	10 ÷ 2200	10 ÷ 3000	10 ÷ 3000
Main motor power	(kW)	37	51	71	74 / 101	37 / 46



# HORIZONTAL BORING AND MILLING MACHINES

2

## FLOOR TYPE



FLOOR TYPE		HCW 2000	HCW 3000	HCW 4000
Spindle diameter	(mm)	150 / 160 / 180	180 / 200 / 225	225 / 250 / 260
Column transverse travel X	(mm)	from 3000	from 3500	from 4000
Headstock vertical travel Y	(mm)	2000 ÷ 5000	2500 ÷ 7000	3000 ÷ 9000
Spindle stroke Z / W	(mm)	1750 / 1250	2000 / 1400	2500 / 1500
Spindle speed range	(min <sup>-1</sup> )	2 ÷ 3500	1 ÷ 3000	1 ÷ 2500
Main motor power	(kW)	64 / 80	103 / 124	120



FLOOR TYPE		FCW 140	FCW 150	FCW 160
Spindle diameter	(mm)	140	150	160 / 180
Column transverse travel X	(mm)	from 4000	from 4000	from 4000
Headstock vertical travel Y	(mm)	2000 ÷ 5000	2000 ÷ 4000	2000 ÷ 6000
Spindle stroke W	(mm)	900	900	1000
Sleeve extension Z axis	(mm)	1000	1200	1500
Spindle speed range	(min <sup>-1</sup> )	10 ÷ 3000	10 ÷ 3000	10 ÷ 3000 / 3500
Main motor power	(kW)	37	52	58 / 74



FLOOR TYPE		HCW 1	HCW 2	HCW 3	HCW 4
Spindle diameter	(mm)	150 / 160	160 / 180 / 200	200 / 225 / 262	260 / 280 / 300
Column transverse travel X	(mm)	from 3000	from 3500	from 4000	from 4500
Headstock vertical travel Y	(mm)	2000 ÷ 5000	2000 ÷ 7000	3000 ÷ 9000	4000 ÷ 10000
Spindle stroke Z / W	(mm)	1200 / 1000	1300 / 1200	1600 / 1500	2000 / 1800
Spindle speed range	(min <sup>-1</sup> )	3000	2500	2000	1600
Main motor power	(kW)	71 / 100	100 / 140	100 / 140	130 / 160





## HORIZONTAL BORING AND MILLING MACHINES

### FLOOR TYPE

**RETOS**  
VARRHSDORF

#### FLOOR TYPE

#### RET 10 P

Spindle diameter	(mm)	100 / 105
Clamping taper	ISO	50
Spindle speed range	(min <sup>-1</sup> )	10 ÷ 3500
Headstock travel Y	(mm)	2000
Column transversal travel X	(mm)	2000 ÷ 12000
Spindle stroke W / Ram stroke Z	(mm)	610 / 650



**FERMAT**

#### FLOOR TYPE

#### WF 13 CNC

#### WRF 130 CNC

#### WRF 150 CNC

#### WRF 160 CNC

#### WRF 160 HEAVY

Spindle diameter	(mm)	130	130	150	160	160
Column transverse travel X	(mm)	4 ÷ 22000	2400 ÷ 28100	2400 ÷ 28100	2400 ÷ 28100	2400 ÷ 28100
Headstock vertical travel Y	(mm)	2000 / 2500 / 3000 / 3500	2000 ÷ 6000	2000 ÷ 6000	2000 ÷ 6000	2000 ÷ 8000
Spindle stroke W / Z	(mm)	730 / 600	730 / 900	1000 / 1000 (1200)	1000 / 1000 (1200)	1000 / 1500
Spindle speed range	(min <sup>-1</sup> )	10 ÷ 3000	10 ÷ 3000	10 ÷ 2800	10 ÷ 2500	10 ÷ 2500
Main motor power	(kW)	37 / 56	37 / 56	51 / 77	60 / 80	60 / 80

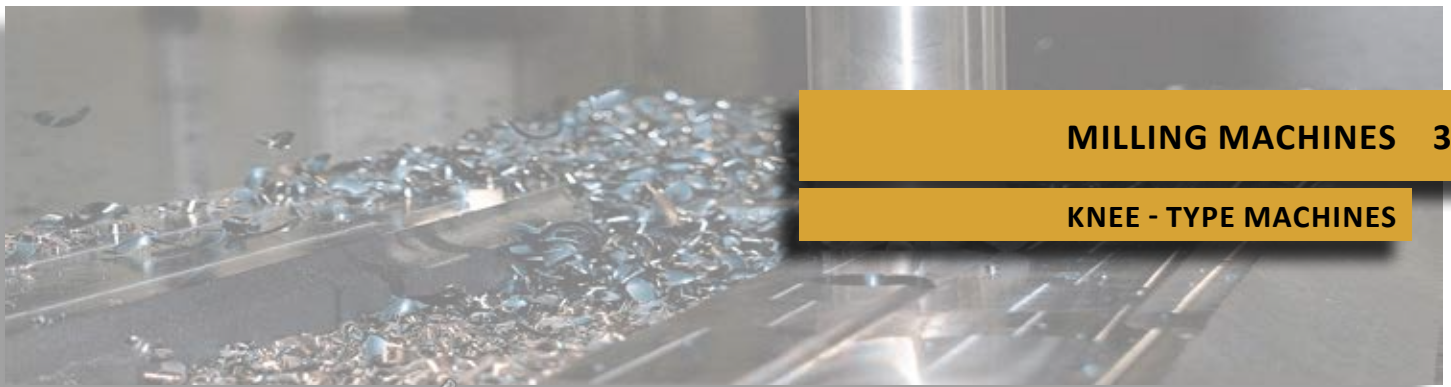

KNEE - TYPE MACHINES		FTU 1000 / FTV 1000 / FTH 1000	FTU 1250 / FTV 1250 / FTH 1250	FTU 1500 / FTV 1500 / FTH 1500	FTU 1600 / FTV 1600 / FTH 1600	FTU 2000 / FTV 2000 / FTH 2000
Table size	(mm)	1500 × 360	1800 × 400	1800 × 500	2200 × 540	2600 × 600
Travels X / Y / Z	(mm)	1000 × 380 × 430	1250 × 540 × 470	1500 × 700 × 470	1600 × 710 × 710	2000 × 710 × 710
Spindle	(ISO)	50	50	50	50	50
Spindle speed	(min <sup>-1</sup> )	40 ÷ 1750	40 ÷ 1750	40 ÷ 1750	1500	1500
Total power output- main drive	(kW)	7,5	7,5	7,5	11	15
Max. table load	(kg)	800	1000	1000	1500	2500



KNEE - TYPE MACHINES		FTU 1000 CNC / FTV 1000 CNC / FTH 1000 CNC	FTU 1250 CNC / FTV 1250 CNC / FTH 1250 CNC	FTU 1500 CNC / FTV 1500 CNC / FTH 1500 CNC	FTU 1600 CNC / FTV 1600 CNC / FTH 1600 CNC	FTU 2000 CNC / FTV 2000 CNC / FTH 2000 CNC
Table size	(mm)	1500 × 360	1800 × 400	1800 × 500	2200 × 540	2600 × 600
Travels X / Y / Z	(mm)	1000 × 350 × 430 (470)	1250 (1500) × 500 × 470 (550)	1500 (1600) × 650 × 470 (550)	1600 × 710 × 710	2000 × 710 × 710
Spindle	(ISO)	50	50	50	50	50
Spindle speed	(min <sup>-1</sup> )	1750 / 2000 / 2500	1750 / 2000 / 2500	1750 / 2000 / 2500	1500	1500
Total power output- main drive	(kW)	7,5	7,5	7,5	11	15
Max. table load	(kg)	800	1000 (1250)	1000 (1250)	1500 (2000)	2000 (2500)



### 3 MILLING MACHINES

#### BED AND GANTRY TYPE

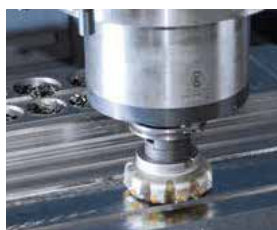

BED AND GANTRY TYPE		MMC 1500 POWER PLUS	MMC 1500 POWER	MMC 1500 SPEED	MMC 1500 SPRINT	MMC 1500 RAPID
Spindle speed range	(min <sup>-1</sup> )	20 ÷ 8000	20 ÷ 10000	20 ÷ 12000	20 ÷ 18000	20 ÷ 24000
Spindle taper		ISO 50 (HSK-A100)	ISO 50	ISO 40 (HSK-A63)	HSK-A63	HSK-A63
Clamping surface	(mm)	1500 × 1300	1500 × 1300	1500 × 1300	1500 × 1300	1500 × 1300
Slide travel in the X axis	(mm)	1500	1500	1500	1500	1500
Table travel in the Y axis	(mm)	1300	1300	1300	1300	1300
Slide travel in the Z axis	(mm)	600	600	600	600	600
Max. weight on table	(kg)	2500	2500	2500	2500	2500
Dimension of the table clamping area- DT	(mm)	720 × 1000	720 × 1000	720 × 1000	720 × 1000	720 × 1000
Table travel in the X axis- DT	(mm)	1500	1500	1500	1500	1500
Cross beam travel in the Y axis- DT	(mm)	1000	1000	1000	1000	1000
Slide travel in the Z axis- DT	(mm)	600	600	600	600	600
Maximum table loading- DT	(kg)	2500	2500	2500	2500	1250



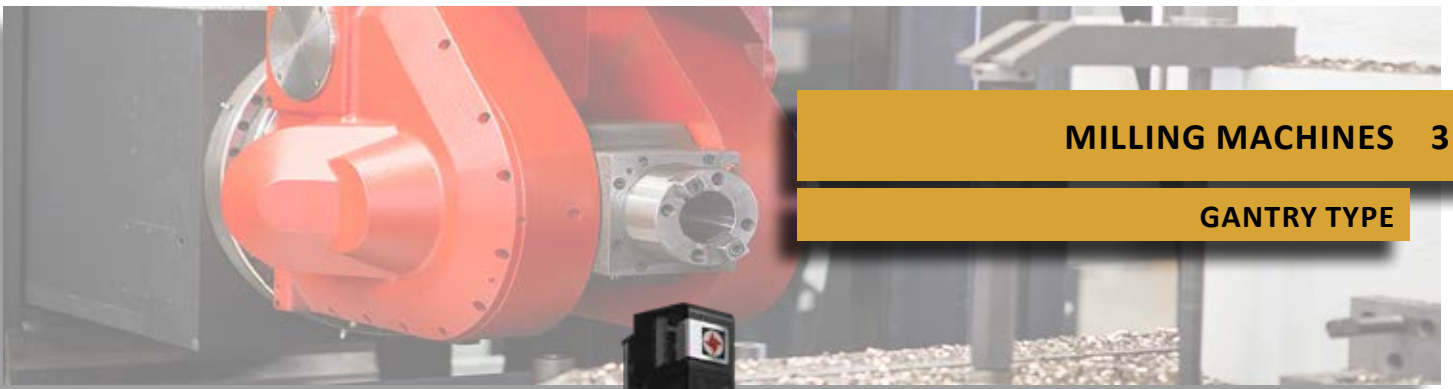

GANTRY TYPE		FRF 200, 250, 300, 400	FRU 200-500	FRU 300-800
Working travel X- cross	(mm)	4000 ÷ 24000	4000 ÷ 22000	4000 ÷ 24000
Working travel Y- cross	(mm)	2900, 3400, 3900, 4900	3500 ÷ 6500	5750 ÷ 10750
Working travel Z- vertical	(mm)	1500	1500 / 2000	1500 / 2000
Working travel W- cross rail	(mm)	-	2000 / 2500 (optional)	2250 / 2800 / 3800 (optional)
Column to column distance	(mm)	2550, 3050, 3550, 4550	3000 ÷ 6000	4000 ÷ 9000
Clearance between table and cross-rail	(mm)	2050	2800 ÷ 3500	3500 ÷ 5500
Motor output	(kW)	30 / 37 / 45	30 / 37 / 45 / 60	60 / 71 / 100 / 113





### 3 MILLING MACHINES

#### GANTRY TYPE



GANTRY TYPE		FRP 150-250	FRP 200-400	FRP 200-450
Working travel X- cross	(mm)	3000 / 4000 / 5000	5500 ÷ 13500	5500 ÷ 13500
Working travel Y- cross	(mm)	2900 / 3400 / 3900	3300 ÷ 5800	3800 ÷ 6800
Working travel Z- vertical	(mm)	1250 / 1500	1500 (2000)	1500 / 2000
Working travel W- cross rail	(mm)	-	2000	2250
Column to column distance	(mm)	2600 / 3100 / 3600	3050 ÷ 4550	3050 ÷ 5550
Clearance between table and cross-rail	(mm)	1800	1800 ÷ 2500	2770
Motor output	(kW)	37	30 / 37 / 45 / 60	60 / 71



GANTRY TYPE		FS 100	FS 125
Working travel X- longitudinal	(mm)	2000 / 3000 / 4000 / 5000	2000 / 3000 / 4000 / 5000
Working travel Y- cross	(mm)	1000	1250
Working travel Z- vertical	(mm)	1500 / 2000	1500 / 2000
Table clamping surface	(mm)	2000 / 3000 / 4000 / 5000 × 1000	2000 / 3000 / 4000 / 5000 × 1250
Feed- range X / Y / Z (V, W)	(mm/min)	1 ÷ 20000 (1 ÷ 30000)	1 ÷ 20000 (1 ÷ 30000)
Motor output	(kW)	22 / 30 / 37	22 / 30 / 37



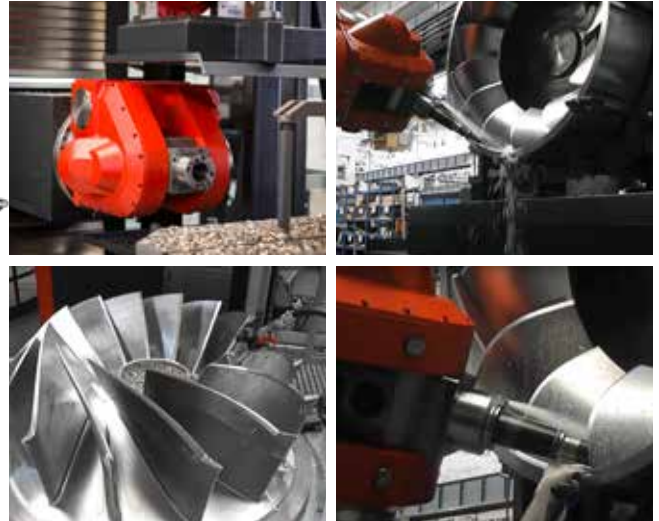

GANTRY TYPE		FUT 150	FUT 150/125	FUT 200	FUT 200/125
Working travel X- longitudinal	(mm)	3000 / 4000 / 5000	3000 / 4000 / 5000	3000 / 4000 / 5000	3000 / 4000 / 5000
Working travel Y- cross	(mm)	2000 / 2500 / 3000	2000 / 2500 / 3000	2000 / 2500 / 3000	2000 / 2500 / 3000
Working travel Z- vertical	(mm)	1500	1500	2000	2000
Working travel W	(mm)		1250		1250
Table clamping surface	(mm)	1600 × 1800 / 1800 × 2200 / 2000 × 2400	1600 × 1800 / 1800 × 2200 / 2000 × 2400	1600 × 1800 / 1800 × 2200 / 2000 × 2400	1600 × 1800 / 1800 × 2200 / 2000 × 2400
Feed- range X / Y / Z (V, W)	(mm/min)	1 ÷ 30000	1 ÷ 30000	1 ÷ 30000	1 ÷ 30000
Motor output	(kW)	37	37	37	37



GANTRY TYPE		FU (Q) 125/150 (200)	FU (Q) 150/200
Working travel X- longitudinal	(mm)	3000 ÷ 20000 (then 1000)	3000 ÷ 20000 (then 1000)
Working travel Y- cross	(mm)	1400 / 2000 / then per 500 up to 5000	1400 / 2000 / then per 500 up to 5000
Working travel Z- vertical	(mm)	1250 / 1500 (2000)	1500 / 2000
Table clamping surface	(mm)	(optional)	(optional)
Feed- range X	(mm/min)	1 ÷ 20000	1 ÷ 24000
Feed- range Y	(mm/min)	1 ÷ 20000	1 ÷ 20000
Feed- range Z	(mm/min)	1 ÷ 20000 / 15000 / 12500	1 ÷ 15000
Motor output	(kW)	30 / 37 / 45	60

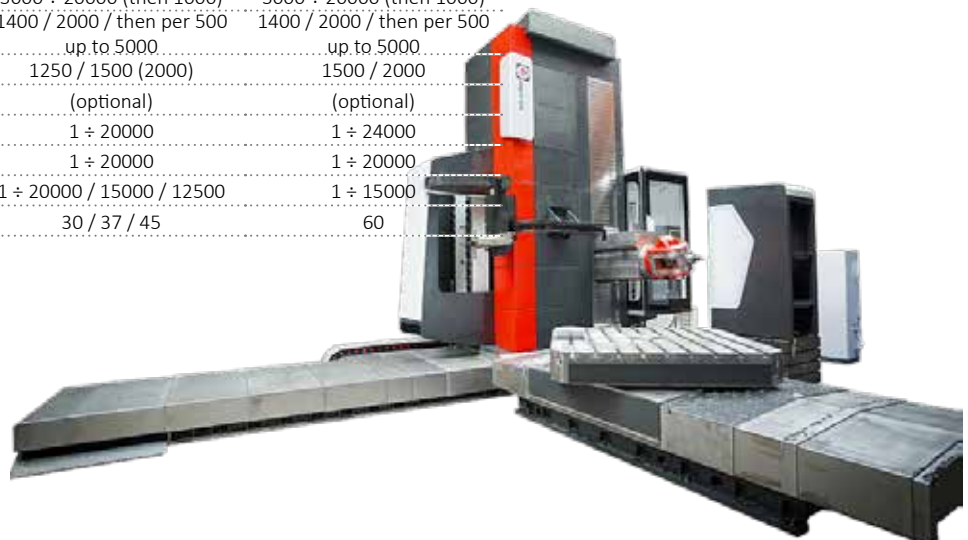



### 3 MILLING MACHINES

#### GRAPHITE MILLING MACHINES

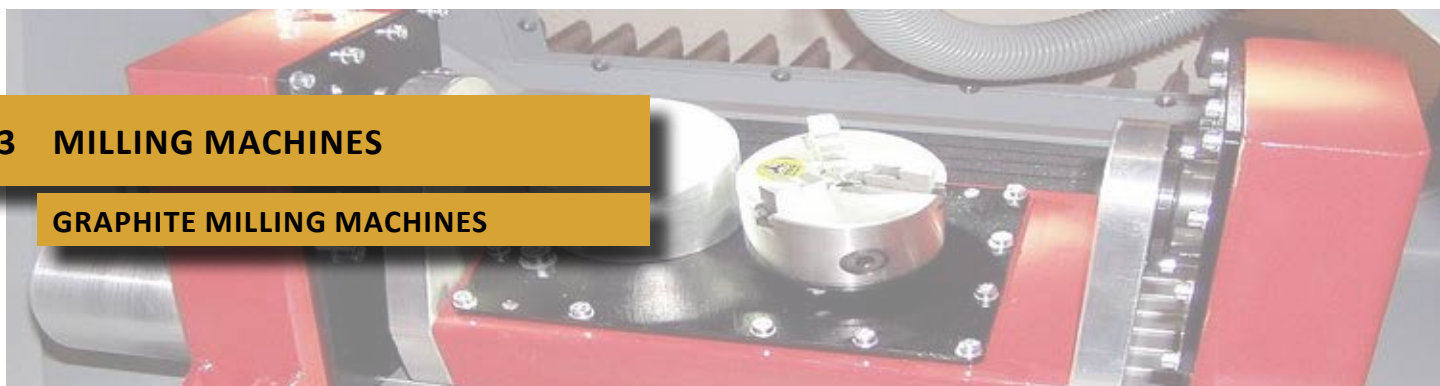

#### GRAPHITE MILLING MACHINES

#### HWT E-422 CNC

Max. machining area (X × Y × Z)	(mm)	400 × 400 × 200 (400 × 400 × 300)
Size of clamping surface (X × Y)	(mm)	500 × 500 × 12 T-rainures
Programmable feed rate	(m/min)	Max. 6 (10)
Programmable step	(mm)	0,003 (servo 0,0005)
Speed range	(min <sup>-1</sup> )	1500 ÷ 6000; 3000 ÷ 12000; 6000 ÷ 24000
Repeat accuracy	(mm)	<0,01
Total accuracy	(mm)	< ±0,02
Max. tool clamping diameter	(mm)	20 (ISO 30)
Spindle motor	(kW)	2 (HSD 5,5)
Outer dimensions (W × D × H)	(mm)	950 × 1250 × 2330
Weight of the machine	(kg)	1300
Workpiece material		graphite, plastics, wood, non-ferrous metals, steel
Max. workpiece weight	(kg)	50



## CYLINDRICAL GRINDING MACHINES



## CYLINDRICAL GRINDING MACHINES

## BUB E CNC

## BHMR CNC

## BHM CNC

Swing diameter	(mm)	320 / 400 / 500	500 (600)	500
Distance between centres	(mm)	1000 / 1500 / 2000	2000 / 3000	2000 / 3000
Maximum weight of the workpiece	(kg)	500	1000	1000
B axis turning range	(°)	+45 / -15 (manual)	+45 / - 225 (automatic)	+15 / - 180 (manual)
Max. quantity of tools		1 + 1	3	1 + 1
Peripheral speed of grinding wheel	(m.s <sup>-1</sup> )	25 ÷ 45 (10 ÷ 50 optional)	10 ÷ 50	10 ÷ 50
Grinding wheel (dia × width × hole)	(mm)	∅ 500 × 80 × ∅ 203	∅ 500 × 80 × ∅ 203	∅ 500 × 80 × ∅ 203
Output of grinding headstock electric motor	(kW)	11	11	11
Machine working accuracy	(µm)	2 ÷ 4	2 ÷ 4	2 ÷ 4



## CYLINDRICAL GRINDING MACHINES

## BUC E CNC

## BHCR CNC

## BHC CNC

Swing diameter	(mm)	630 / 850	630 / 850 / 1000	630 / 850 / 1000
Distance between centres	(mm)	2000 / 3000 / 4000 / 5000	2000 / 3000 / 4000 / 5000 / 6000	2000 / 3000 / 4000 / 5000 / 6000
Maximum weight of the workpiece	(kg)	3000	4000 (5000)	4000 (5000)
B axis turning range	(°)	+30 / - 10 (manual)	+45 / - 225 (automatic)	+30 / - 30 (manual)
Max. quantity of tools		-	3	1 + 1
Peripheral speed of grinding wheel	(m.s <sup>-1</sup> )	25 ÷ 45 (10 ÷ 50 optional)	10 ÷ 50	10 ÷ 50
Grinding wheel (dia × width × hole)	(mm)	∅ 750 × 100 × ∅ 305	∅ 750 × 100 × ∅ 305	∅ 750 × 100 × ∅ 305
Output of grinding headstock electric motor	(kW)	18,5	18,5	18,5
Machine working accuracy	(µm)	2 ÷ 4	2 ÷ 4	2 ÷ 4



## 5 DRILLING MACHINES

### BENCH DRILLING MACHINES



### HELTOS

BENCH DRILLING MACHINES		VS 20.6 VEGA	VS 25-260 TAURUS	VS 40 SPRINT	VS 40-420/430 CASTOR
Drilling diameter 600 MPa	(mm)	20	25	40	40
Drilling depth	(mm)	160	180	220	220
Cone in MORSE spindle	(Morse)	3	3	4	4
Gear type		flexible (belt)	flexible (belt)	mechanical	elastic
Number of speed steps		2	2	without degrees	12/18
Speed range	(min <sup>-1</sup> )	180 ÷ 3700	80 ÷ 2800	45 ÷ 2800	56 ÷ 2800
Feed - number of steps		manual	4	manual	4
Feed - range	(mm/r.)	0	0,08 ÷ 0,32	0,11 ÷ 0,45	0,11 ÷ 0,45
Electric motor output	(kW)	1,1	1,1	2,2	2,2 / 2,3

BENCH DRILLING MACHINES		VS 25-290 SIRIUS	VS 32 HERKULES	VS 32 SATURN	VS 20.6 CANIS
Drilling diameter 600 MPa	(mm)	25	32	32	20
Drilling depth	(mm)	180	180	180	160
Cone in MORSE spindle	(Morse)	3	4	4	3
Gear type		mechanical	elastic	mechanical	flexible (belt)
Number of speed steps		2	2	2	0
Speed range	(min <sup>-1</sup> )	80 ÷ 2800	80 ÷ 2800	80 ÷ 2800	250 ÷ 3700
Feed - number of steps		4	4	4	manual
Feed - range	(mm/r.)	0,08 ÷ 0,32	0,08 ÷ 0,32	0,08 ÷ 0,32	0
Electric motor output	(kW)	1,1	1,5	1,5	1



**WEILER**

PORTABLE RADIAL DRILLING MACHINE	VO 75	VO 100 / 104	VOM 50
Drilling capacity in steel 600 MPa t.s.	(mm) 75	100	50
Drilling capacity in grey cast iron 250 MPa t.s.	(mm) 90	110	65
Max. motion of the drilling head along the arm / Max. motion of the arm (VOM 50)	(mm) 1614	2015 / 3470	900
Max. vertical displacement of the arm	(mm) 950	1155 / 1535	1250
Speed range	(min <sup>-1</sup> ) 11,2 ÷ 2000	9 ÷ 2800	16 ÷ 800
Main electric motor output	(kW) 7,5	11 (15)	4



**MOOS**

INDRUSTRIAL RADIAL COLUMN DRILLING MACHINES	VR 35	VR 40	VR 50	VR 63	VR 80	VR 100	VR 132
Drilling capacity in steel 600 MPa t.s.	(mm) 35	40	50	63	80	100	132
Distance spindle column	(mm) 300 ÷ 1000	290 ÷ 1285	350 ÷ 1600	450 ÷ 1600	530 ÷ 2530	570 ÷ 3150	600 ÷ 4200
Max. motion of the drilling head along the arm	(mm) 700	995	1250	1550	2000	2580	3600
Taper in spindle	(MORSE) 4	4	5	5	6	6	metric 80
Speed range	(min <sup>-1</sup> ) 40 ÷ 1928	40 ÷ 1500	25 ÷ 2000	25 ÷ 1600	16 ÷ 1250	8 ÷ 1000	6,3 ÷ 800
Main electric motor output	(kW) 2,2	3	4	5,5	7,5	15	18,5



## 6 MACHINING CENTRES

### VERTICAL MACHINING CENTRES



**TAJMAC - ZPS**

3 AXES MACHINING CENTER		MCFV 1060i	MCFV 1260i	MCFV 1680i	MCFV 2080i
Table- working area	(mm)	1320 × 620	1500 × 620	1800 × 780	2200 × 780
Travels X / Y / Z	(mm)	1050 × 640 × 800	1300 × 640 × 800	1700 × 840 × 840	2100 × 840 × 840
Speed range	(min <sup>-1</sup> )	8000 / 10000 / 12000 / 15000 / 18000	8000 / 10000 / 12000 / 15000 / 18000	8000 / 10000 / 12000 / 15000 / 18000	8000 / 10000 / 12000 / 15000 / 18000
Table - max. load	(kg)	1350	1350	2500	3000
Total power output- main drive	(kW)	19,5 / 22,5 / 25	19,5 / 22,5 / 25	17 / 20 / 25	17 / 20 / 25
Number of tool pots in magazine	(pcs)	30	24	24	24



**TAJMAC - ZPS**

3 AXES MACHINING CENTER (PORTAL)		MCV 1210	MCV 1220	MCV 2318	MCG 1000 5XT
Table- working area	(mm)	1200 × 1000	1200 × 2000	2520 × 1600	∅ 1000 (800)
Travels X / Y / Z	(mm)	1000 × 1800 × 600	1000 × 1800 × 600	2300 × 1500 × 1050	1200 × 1000 × 700
Speed range	(min <sup>-1</sup> )	15000 (18000)	15000 (18000)	18000 (12000)	12000 ÷ 18000
Table- Max. load	(kg)	3000	2 × 3000	10000	1300
Total power output- main drive	(kW)	31 (32)	31 (32)	27 (31)	31 (37)
Number of tool pots in magazine	(pcs)	30	50 (130)	50	50 (30)

TRENS

3 AXES MACHINING CENTER	MC1040V	
Table- working area	(mm)	1200 × 500
Travel X / Y / Z	(mm)	1040 × 540 × 600
Speed range	(min <sup>-1</sup> )	12000
Table- Max. load	(kg)	850
Total power output- main drive	(kW)	15 / 25
Number of tool pots in magazine	(pcs)	24



MAS  
KOVČEVIT MAŠ  
making your future

3 AXES MACHINING CENTER		MCV 750 RAPID	MCV 750 SPRINT	MCV 750 SPEED
Working range X / Y / Z	(mm)	750 × 500 × 500	750 × 500 × 500	750 × 500 × 500
Clamping surface	(mm)	1000 × 640	1000 × 640	1000 × 640
Max. weight on table	(kg)	650	650	650
Spindle cone	-	HSK- A63	HSK- A63	HSK- A63 (ISO 40)
Max. spindle speed	(min <sup>-1</sup> )	24000	18000	12000
Spindle motor output SIEMENS (S1/S6- 40%)	(kW)	19 / 26,7	25 / 35	33 / 45
Nominal torque (S1/S6- 40%)	(Nm)	60 / 86	86 / 120	157 / 215
Tool magazine capacity	-	24	24	24
Control system	-	HEIDENHAIN	HEIDENHAIN	HEIDENHAIN





## 6 MACHINING CENTRES

### VERTICAL MACHINING CENTRES



KOVČOVIT MAS

#### MILLING CENTERS VERTICAL 3 AXES

#### MCV 1100 (POWER, SPEED, SPRINT)

#### MCV 1400 (POWER, SPEED, SPRINT)

#### MCV 2220 POWER, SPEED, SPRINT

Working range X / Y / Z	(mm)	1100 x 650 x 750	1400 x 650 x 750	2200 x 860 x 860
Clamping surface	(mm)	1300 x 650	1600 x 650	2400 x 850
Max. weight on table	(kg)	1250	1250	3500
Spindle cone	-	ISO 40	ISO 40	ISO 40, ISO 50, HSK 63
Max. spindle speed	(min <sup>-1</sup> )	20 ÷ 12000	20 ÷ 12000	8000 / 12000 / 18000
Spindle motor output (S1/S6- 40%)	(kW)	21,5 / 32,3	21,5 / 32,3	28 / 43, 32 / 48, 25 / 35
Nominal torque (S1/S6- 40%)	(Nm)	157 / 236	157 / 236	406 / 623, 130 / 200, 86 / 120
Tool magazine capacity	-	24 (40)	24 (40)	40
Control system	-	HEIDENHAIN / SIEMENS	HEIDENHAIN / SIEMENS	HEIDENHAIN



KOVČOVIT MAS



#### MILLING CENTERS VERTICAL 3 AXES

#### MCV 1270 RAPID

#### MCV 1270 SPRINT

#### MCV 1270 SPEED

#### MCV 1270 POWER

Working range X / Y / Z	(mm)	1270 x 610 x 720	1270 x 610 x 720	1270 x 610 x 720	1270 x 610 x 720
Clamping surface	(mm)	1500 x 670	1500 x 670	1500 x 670	1500 x 670
Max. weight on table	(kg)	1200	1200	1200	1200
Spindle cone	-	HSK- A63	HSK- A63	HSK- A63 (ISO 40)	ISO 50 (ISO 40)
Max. spindle speed	(min <sup>-1</sup> )	24000	18000	12000	8000
Spindle motor output (S1/S6- 40%)	(kW)	19 / 26,7	25 / 35	33 / 45	28 / 43
Nominal torque (S1/S6- 40%)	(Nm)	60 / 86	86 / 120	157 / 215	406 / 623
Tool magazine capacity	-	30	30	30	24 / 30
Control system	-	HEIDENHAIN	HEIDENHAIN	HEIDENHAIN	HEIDENHAIN



KOVOSVIT MAŠ  
MACHINING your future

MILLING CENTERS VERTICAL 3 AXES		MCV 754 QUICK	MCV 800 QUICK	MCV 1016 QUICK
Working range X / Y / Z	(mm)	754 × 500 × 550	800 × 500 × 550	1016 × 610 × 710
Clamping surface	(mm)	1000 × 500	1000 × 500	1300 × 600
Max. weight on table	(kg)	400	600	700
Spindle motor output SIEMENS (S1/S6- 40%)	(kW)	9 / 13	10 / 14	17 / 25
Max. spindle speed	(min <sup>-1</sup> )	10000	12000	10000
Spindle cone		ISO 40	ISO 40	ISO 40
Tool magazine capacity	-	24	24	24
Control system	-	HEIDENHAIN / FANUC / SIEMENS	HEIDENHAIN / FANUC / SIEMENS	HEIDENHAIN / FANUC / SIEMENS





## 6 MACHINING CENTRES

### VERTICAL MACHINING CENTRES



KOVČEVIT MAS  
MACHINING YOUR BUSINESS



MILLING CENTERS VERTICAL 5 AXES		MCU 450VT -5X	MCU 700VT -5X	MCU 700V -5X	MCU 1100V -5X	MCU 1100VT -5X
Rotary table top dia	(mm)	500	630 (800)	630 (800)	1150 x 900	1200
Tilting axis A	(°)	±120	150 (+30°/-120°)	150 (+30°/-120°)	175° (+45°/-130°)	175° (+45°/-130°)
Rotary axis C	(°)	360°	360°	360°	360°	360°
Max. weight on table	(kg)	500 (350)	850	850	2200	1700
Working range X / Y / Z	(mm)	500 x 800 x 520	700 x 820 x 550	700 x 820 x 550	1100 x 1550 x 1000	1100 x 1550 x 1000
Max. spindle speed (rpm)	(min <sup>-1</sup> )	12000 / 18000 / 24000	10000 / 12000 / 18000 / 24000	10000 / 12000 / 18000 / 24000	10000 / 12000 / 18000 / 24000	10000 / 12000 / 18000 / 24000
Spindle motor output (S1/S6- 40%)	(kW)	---	---	---	---	---
Nominal torque (S1/S6- 40%)	(Nm)	---	---	---	---	---
Number of pots in tool magazine	-	30 (60)	---	---	60 [120, 240]	60 [120, 240]



KOVČEVIT MAS  
MACHINING YOUR BUSINESS



MILLING CENTERS VERTICAL 5 AXES		MCV 1000 POWER 5AX	MCV 1000 SPEED 5AX	MCV 1000 SPRINT 5AX	MCV 1000 RAPID 5AX
Rotary table top dia	(mm)	520	520	520	520
Tilting axis A	(°)	± 110°	± 110°	± 110°	± 110°
Rotary axis C	(°)	360°	360°	360°	360°
Max. weight on table	(kg)	400	400	400	400
Working range X / Y / Z	(mm)	800 x 590 x 480	800 x 590 x 520	800 x 590 x 520	800 x 590 x 520
Max. spindle speed (rpm)	(min <sup>-1</sup> )	8000	12000	18000	24000
Spindle motor output SIEMENS (S1/S6- 40%)	(kW)	28 / 43	33 / 48	25 / 35	19 / 26,7
Nominal torque (S1/S6- 40%)	(Nm)	406 / 623	130 / 200	86 / 120	60 / 86
Number of pots in tool magazine	-	24 (40)	30 (60)	30 (60)	30 (60)

WE ALSO OFFER THESE MACHINES IN A 3-AXIS VERSION



HORIZONTAL MACHINING CENTRES		H 500	H 630	H 800	H 800 Five Axis	H 1000	H 1000 Five Axis
Table - working area	(mm)	500 x 500	630 x 630	800 x 800	800 x 630 (ø 800)	1000 x 1000	800 x 800 (ø 940)
Travels X / Y / Z	(mm)	560 x 560 x 560	750 x 700 x 770	1010 x 1050 x 1010	1000 x 1050 x 1000	1400 x 1050 x 1200	1400 x 1050 x 1200
Speed range	(min <sup>-1</sup> )	10000 (15000 ÷ 18000)	8000	8000 (4500)	14000 (15000 ÷ 18000)	8000	18000 (14000)
Table - max. load	(kg)	300	800	2500	1000	2500	2500
Total power output - main drive	(kW)	30 (31)	30 (31,37)	43 (25)	31 (37)	43	31 (37)
Number of tool pots in magazine	-	45	56	56	56	56	56





## 7 GEAR CUTTING MACHINES

### GEAR HOBBING MACHINE

### GEAR SHAPING MACHINE



#### GEAR HOBBING MACHINE

#### OFA 32 CNC 6

#### OFA 75 CNC 6

#### OFA 100 CNC 6

Max. module of milled gear	(mm)	7	12 (14)	14 (16)
Max. dia of milled gear	(mm)	320	750 (900)	1050 (1120)
Max. carriage path	(mm)	300	630	630
Max. / min. distance of tool axis from table axis	(mm)	300 / 40	580 / 60	625 / 80
Main motor power	(kW)	12	28	28



#### GEAR SHAPING MACHINE

#### OHA 50 CNC 5

Max. module of shaped gear	(mm)	8
Max. diameter of shaped gear	(mm)	500
Max. width of shaped gear	(mm)	125
Max. table load	(kg)	300
Max. distance of the arm axis to the table axis	(mm)	355
Main motor power	(kW)	17



BENCH HYDRAULIC PRESSES

ECCENTRIC PRESSES & PRESS BRAKES



BENCH HYDRAULIC PRESSES		ZHW 6	ZHW 10	ZHW 16	ZHW 25	ZHW 40
Pressure Force	(kN)	60	100	160	250	400
Output	(kW)	1,5	3	4	5,5	11
Ram stroke	(mm)	160	200	200	250	250
Ram surface	(mm)	180 × 250	200 × 280	200 × 280	250 × 350	250 × 470
Throat (Gap)	(mm)	160	200	200	250	315



ECCENTRIC PRESSES	LEN 10 C	LEN 25 C	LEN 40 C	LEN 63 C	LEXN 100 C	
Nominal press force	(kN)	100	250	400	630	1000
Adjustability of stroke	(mm)	6 ÷ 65	8 ÷ 85	8 ÷ 95	10 ÷ 105	10 ÷ 125
Ram surface	(mm)	280 × 180	355 × 220	400 × 250	450 × 280	560 × 360
Table surface	(mm)	450 × 320	560 × 450	660 × 530	800 × 630	1000 × 640
Grip	(mm)	225	265	295	335	380
Total power input- main drive	(kW)	1,8 / 3,6	2,5 / 5	3,5 / 7	3,5 / 7	5,6 / 11



HYDRAULIC EDGING PRESS	HOL 40 NC	HOL 40 E	
Type of control	numeric	manual	
Bending power	(t)	40	40
Max. sheet thickness	(mm)	0,4 ÷ 6	0,4 ÷ 6
Working table width	(mm)	800, 1250, 1500, 2000	
Distance between the punch and die	(mm)	310	
Max. punch stroke	(mm)	100	
Bending feed	(mm/s)	10	
Bending feed (to the top dead centre)	(mm/s)	12	
Clamping of tools		manual	
Camber		manual	
Rear holder- range of adjustment	(mm)	5 ÷ 420 numeric	5 ÷ 420 manual
Rear holder feed	(mm/s)	40	
Main motor output	(kW)	40	
Max. size of punch	(mm)	50	





## 8 PRESS MACHINES

### FORGING PRESSES



FORGING PRESSES		LZK 1000 P/SH	LZK 1600 P/SH	LZK 2500 P/SH
Forming force	(MN)	10,0	16,0	25,0
Shut height	(mm)	620	760	905
Passage	(mm)	1040	1230	1410
Bed area	(mm)	1000 × 950	1180 × 1120	1340 × 1400
Ram area	(mm)	968 × 750	1138 × 920	1320 × 1100
Hydraulic ram adjustment	(mm)	10	10	10
Stroke / Number of strokes	(mm/min)	220 / 100	280 / 85	320 / 65
Total installed output	(kW)	65,0	85,0	145,0



FORGING PRESSES		LZK 3150 B	LZK 4000 B	LZK 5000	LZK 6500
Forming force	(MN)	31,5	40,0	50,0	65,0
Shut height	(mm)	1000	1000	1100	1150
Passage	(mm)	1580	1580	1670	2100
Bed area	(mm)	1520 × 1520	1520 × 1600	1710 × 1710	1950 × 1900
Ram area	(mm)	1450 × 1450	1470 × 1500	1540 × 1650	1900 × 1700
Hydraulic ram adjustment	(mm)	20	20	20	20
Stroke / Number of strokes	(mm/min)	360 / 65	380 / 60	400 / 55	450 / 40
Total installed output	(kW)	175,0	220,0	330,0	420,0



FORGING PRESSES		LMZ 1000 A/S	LMZ 1600 A/S	LMZ 2500	LMZ 4000	LMZ 6500
Forming force	(MN)	10,0	16,0	25,0	40,0	65,0
Shut height	(mm)	660	800	910	1100	1280
Passage	(mm)	1120	1290	1470	1850	2300
Bed area	(mm)	1080 × 950	1240 × 1150	1420 × 1400	1800 × 1700	2200 × 2000
Ram area	(mm)	1010 × 850	1160 × 1035	1350 × 1250	1550 × 1700	2100 × 1890
Hydraulic ram adjustment	(mm)	10	10	10	20	20
Stroke / Number of strokes	(mm/min)	220 / 115	270 / 85	320 / 70	380 / 60	480 / 45
Total installed output	(kW)	65,0	85,0	145,0	220,0	410,0



FORGING PRESSES		CKV 630	CKV 1000	CKV 1600	CKV 2500
Nominal forming force	(MN)	6,3	10	16	25
Return force	(MN)	0,6	1,5	1,9	2,45
Stroke	(mm)	1000	1250	1400	1800
Maximum opening	(mm)	2000	2500	2800	3900
Maximum eccentricity	(mm)	150	250	250	300
Distance between columns	(mm)	1370	2040	2200	2940
Max. height above floor level	(mm)	5600	7400	8000	9800
Max. depth under floor level	(mm)	1400	1700	1900	2600
Total length	(mm)	8620	10700	12700	15800
Total width	(mm)	10070	11650	13500	16100
Forming speed max.	(mm/s)	120	120	120	120
Number of smoothing strokes	(1/min)	100 ÷ 120	95 ÷ 110	95 ÷ 110	80 ÷ 100



FORGING PRESSES		CKV 3200	CKV 4000	CKV 6300	CKV 8000	CKV 12000
Nominal forming force	(MN)	32	42	60	84	120
Return force	(MN)	3,2	3,9	5,6	8	9,2
Stroke	(mm)	2000	2250	2500	3000	3000
Maximum opening	(mm)	4600	4500	6000	7000	6500
Maximum eccentricity	(mm)	300	250	250	250	250
Distance between columns	(mm)	3400	3000	4000	4300	4700
Max. height above floor level	(mm)	11200	12500	14700	17800	18900
Max. depth under floor level	(mm)	2800	4500	5500	6500	8000
Total length	(mm)	19800	21500	23200	24000	42900
Total width	(mm)	20500	21000	21750	22300	28000
Forming speed max.	(mm/s)	120	70	63	63	60
Number of smoothing strokes	(1/min)	70 ÷ 90	70 ÷ 80	60 ÷ 70	50 ÷ 60	45 ÷ 55



## 8 PRESS MACHINES

### FORGING PRESSES



FORGING PRESSES		CKW 630	CKW 1000	CKW 1600	CKW 2500
Nominal forming force	(MN)	6,3	10	16	25
Return force	(MN)	1,1	1,9	2,8	4,8
Stroke	(mm)	800	1000	1250	1600
Maximum opening	(mm)	1800	2250	2800	3600
Maximum eccentricity	(mm)	140	180	200	250
Distance between columns	(mm)	2250	2800	3500	4500
Lift of forging plate in longitudinal direction	(mm)	±800	±1000	±1250	±1600
Max. height above floor level	(mm)	3065	3920	5340	6830
Max. depth under floor level	(mm)	3830	4670	6340	8100
Total length	(mm)	8620	10700	12700	15800
Total width	(mm)	10070	11650	13500	16100
Forming speed max.	(mm/s)	100	100	100	95
Number of smoothing strokes	(1/min)	100 ÷ 120	90 ÷ 100	90 ÷ 110	80 ÷ 100
Total installed power input	(1/min)	650	900	1360	2150

FORGING PRESSES		CKW 3200	CKW 4000	CKW 6300	CKW 7000
Nominal forming force	(MN)	32	40	65	70
Return force	(MN)	5	8,9	13,7	13,7
Stroke	(mm)	1800	2500	2500	2800
Maximum opening	(mm)	4000	5100	6100	6400
Maximum eccentricity	(mm)	280	400	500	500
Distance between columns	(mm)	5000	3400	4700	4700
Lift of forging plate in longitudinal direction	(mm)	±1800	±1700	±3000	±3000
Max. height above floor level	(mm)	7450	8700	10400	13500
Max. depth under floor level	(mm)	8150	11000	13500	16500
Total length	(mm)	19800	21500	23200	24000
Total width	(mm)	20500	21000	21750	22300
Forming speed max.	(mm/s)	75	70	63	63
Number of smoothing strokes	(1/min)	85 ÷ 90	70 ÷ 80	60 ÷ 70	60 ÷ 65
Total installed power input	(1/min)	2720	3200	4600	5000

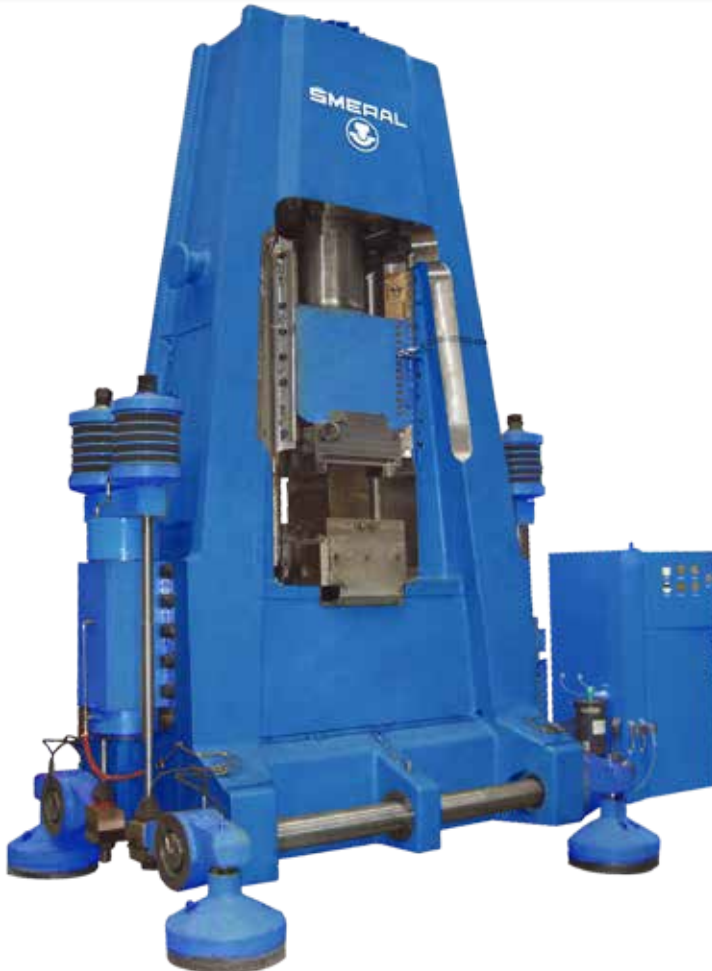

HYDRO-PNEUMATICAL DIE HAMMER		KHZ 2A	KHZ 4A	KHZ 8A
Nominal forming energy	(kJ)	20	40	80
The stroke of ram	(mm)	400	500	600
Distance	(mm)	400	500	600
Hammer width	(mm)	3100	3100	3500
Hammer depth	(mm)	2300	2300	2500
Lower ejector force	(kN)	50	60	80
Lower ejector stroke	(mm)	30	40	40
Electro-engine output	(kW)	30	55	110
Smallest total height of dies	(mm)	250	350	400
The spanning measures in holders	(mm)	286 × 440	300 × 570	342 × 670
Number of strokes	(1/mn)	20	18	16
Height of the hammer above the floor	(mm)	3100	3645	3945
Total height of the hammer	(mm)	4000	4575	5215
Hydraulic oil working pressure	(Mpa)	16	16	16
Nominal inlet air pressure	(Mpa)	0,6	0,6	0,6
Total weight of the hammer	(kg)	24000	42000	74000



## 9 SPECIAL MACHINES

### EQUIPMENT FOR SCRAP CUTTING

**ZDAS**

EQUIPMENT FOR SCRAP CUTTING		CNS 320 K	CNS 400 K
Charging chamber width	(mm)	1200	1600
Max. charging chamber height	(mm)	2060	2250
Charging chamber length	(mm)	2300	2480
Holder width	(mm)	1200	1600
Max. lift of the holder	(mm)	800	800
Max. lift of the tool slide	(mm)	800	800
Max. cutting capacity	(MN)	3,1	4,0
Max. force of the holder	(MN)	1,2	1,2
Oil working pressure	(MPa)	32	32
Nominal output of diesel engine	(kW)	74	74
Engine operating speed	(1/min)	2200	2200
Consumption of diesel oil per 1 tonne of scrap	(l)	2 ÷ 2,5	1,8 ÷ 2
Max. diameter cut	(mm)	95	110
Number of cuts	(1/min.)	3,5	1,8 ÷ 2,7
Output when cutting lengths 400 mm	(t/h)	4 ÷ 7	6 ÷ 9
Max. speed of the holder	(mm/s)	260	260



**ZDAS**

EQUIPMENT FOR SCRAP CUTTING		CNS 800-100-CV2	CNS 1100-100-CV2	CNS 1600-100-CV2
Cutting capacity	(kN)	8000	11000	16000
Holder force	(kN)	3000	3000	4000
Force of jaw cylinders	(kN)	2x 1700	2x 2200	2x 2200
Force of cover cylinders	(kN)	2x 1700	2x 2200	2x 2200
Force of pusher cylinders	(kN)	2000	2500	1200
Charging chamber length	(mm)	6000	8000	8000
Charging chamber width	(mm)	2000	2500	2500
Charging chamber height	(mm)	2000	2000	2000
Bale height	(mm)	700	700	900
Bale width	(mm)	900	900	900
Max. strength of material processed	(MPa)	440	440	440
Max. diameter cut	(mm)	170	200	240
Max. square cut	(mm)	150 x 150	180 x 180	210 x 210
Max. sheet metal cut	(mm)	100 x 900	120 x 900	140 x 900
Max. wall thickness of baled material	(mm)	6	6	6
Number of cuts	(1/min.)	4 ÷ 7	4,2 ÷ 6,9	3,2 ÷ 5,6
Installed power input of the main pumps	(kW)	4x 75	6x 75	6x 75
Shears output	(t/h)	24 ÷ 34	31 ÷ 44	23 ÷ 35

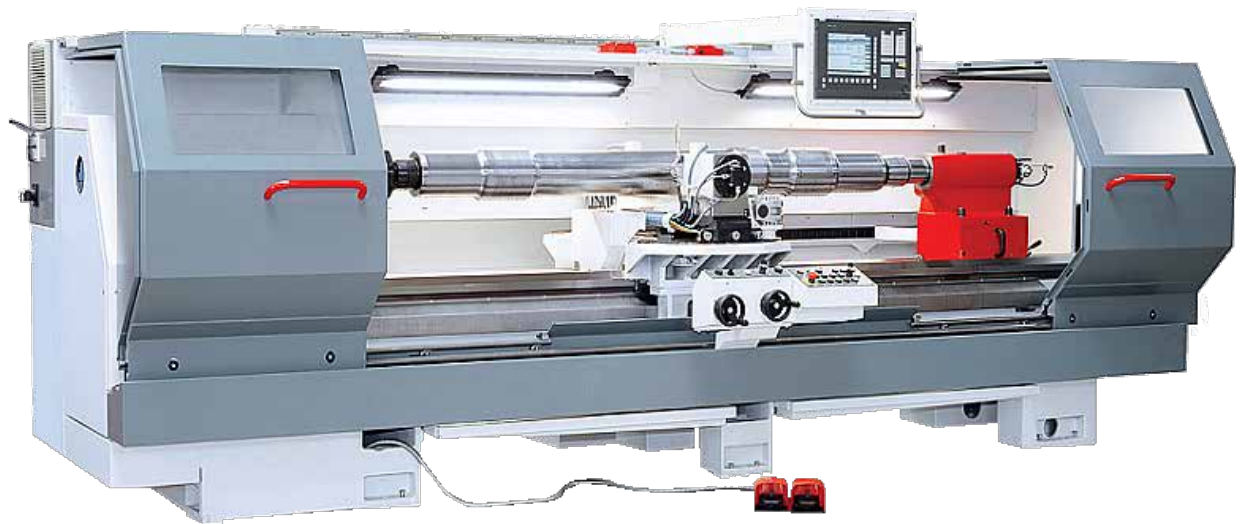

KOVOSVIT MAŠ

## COLD ROLL HARDENING MACHINE

## ROLLER 2800 CNC

Max. diameter without the use of tilting axis B	(mm)	300
Max. diameter with the use of tilting axis B $\pm 30^\circ$	(mm)	280
Max. diameter with the use of tilting axis B $\pm 35^\circ$	(mm)	250
Maximum lift of the rolling head	(mm)	112
Range of rolling force	(kN)	2,5 ÷ 50
Max. force of rolling with the use of tilting axis B	(kN)	20
Max. force of rolling without the use of tilting axis B	(kN)	50
Distance between centres	(mm)	2876
Maximum weight of the workpiece	(kg)	1000





Incoterms 2020 Overview  
Breakdown of Seller's and Buyer's Responsibilities

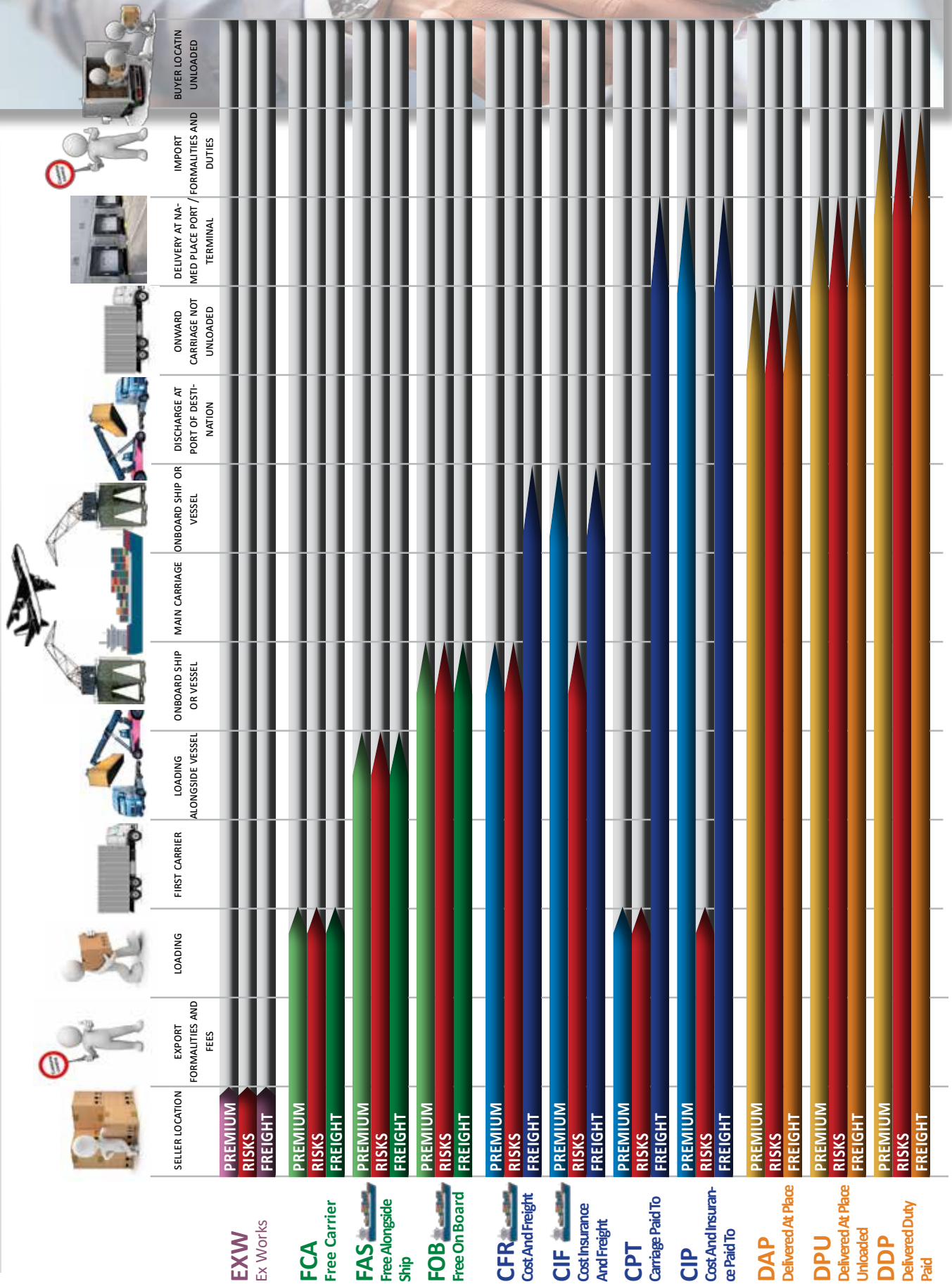



---

⇒ Solution tailored to customer's needs

---

⇒ Door-to-door delivery

---

⇒ All-risk insurance

---

⇒ Professional assembly

---

⇒ Personnel training

---

⇒ Technical assistance

---

⇒ Spare parts deliveries

---

⇒ Special accessories

---

⇒ Overhaul repairs and modernization

---

„Machine delivery is not the final stage for us, on the contrary, we are ready to assist to the client during the whole period of its operation, thus securing satisfaction and full functionality of supplied machine & equipment.”

Strojimport Team



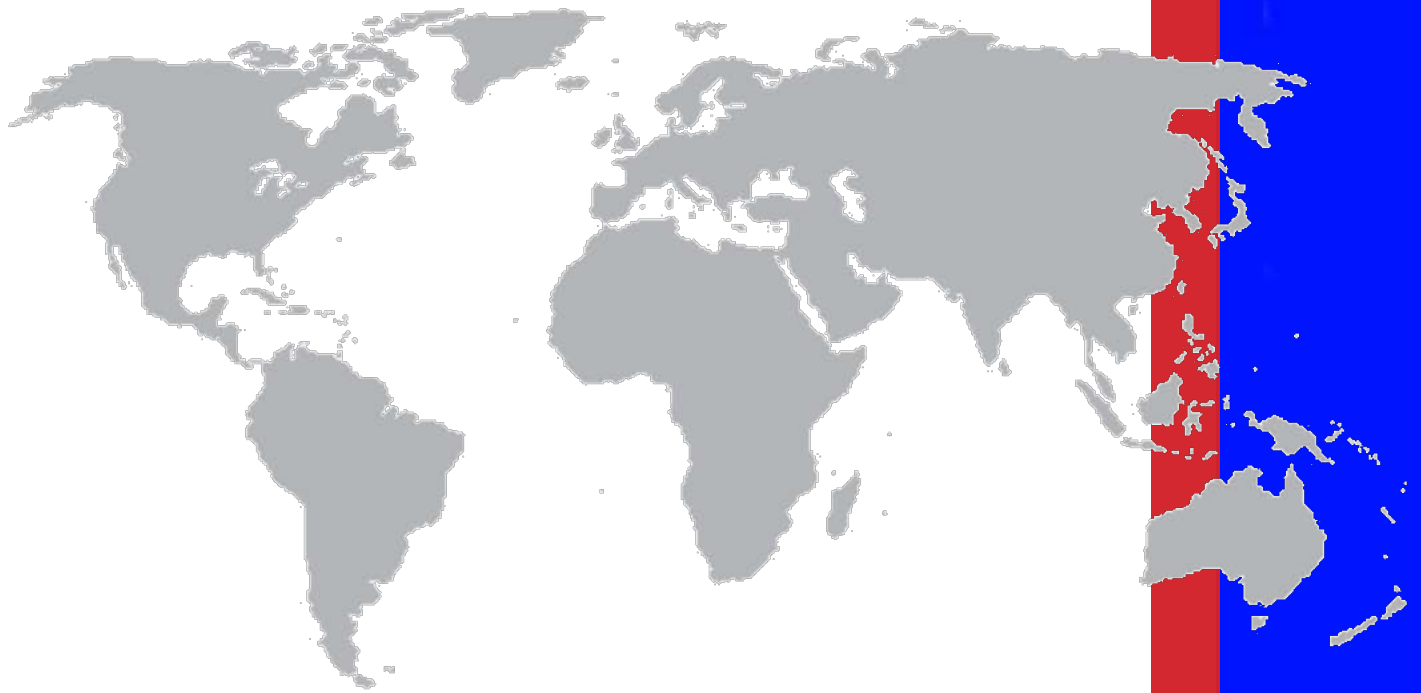

**STROJIMPORT a.s.**  
U Nákladového nádraží 3146/6  
130 00 Praha 3, CZECH REPUBLIC  
Tel. +420 222 863 216  
E-mail: [marketing@strojimport.cz](mailto:marketing@strojimport.cz)  
[www.strojimport.com](http://www.strojimport.com)

DT 29-07-2021

CATALOGUE MACHINERY 2021 / 2022

**Strojimport**  
TOSULIN GROUP